



DIGITAL VOICE PROTECTION (DVP™)

Code Inserter

Models T3010BX and T3010AX



Instruction Manual

68P81060E35-C

**COMMERCIAL WARRANTY
(STANDARD)**

Motorola radio communications products are warranted to be free from defects in material and workmanship for a period of ONE (1) YEAR, (except for crystals and channel elements which are warranted for a period of ten (10) years) from the date of shipment. Parts, including crystals and channel elements, will be replaced free of charge for the full warranty period but the labor to replace defective parts will only be provided for One Hundred-Twenty (120) days from the date of shipment. Thereafter purchaser must pay for the labor involved in repairing the product or replacing the parts at the prevailing rates together with any transportation charges to or from the place where warranty service is provided. This express warranty is extended by Motorola Communications and Electronics, Inc., 1301 E. Algonquin Road, Schaumburg, Illinois 60196, to the original purchaser only, and only to those purchasing for purpose of leasing or solely for commercial, industrial, or governmental use.

THIS WARRANTY IS GIVEN IN LIEU OF ALL OTHER WARRANTIES EXPRESS OR IMPLIED WHICH ARE SPECIFICALLY EXCLUDED, INCLUDING WARRANTIES OF MERCHANTABILITY OR FITNESS FOR A PARTICULAR PURPOSE. IN NO EVENT SHALL MOTOROLA BE LIABLE FOR INCIDENTAL OR CONSEQUENTIAL DAMAGES TO THE FULL EXTENT SUCH MAY BE DISCLAIMED BY LAW.

In the event of a defect, malfunction or failure to conform to specifications established by seller, or if appropriate, to specifications accepted by Seller in writing, during the period shown, Motorola, at its option, will either repair or replace the product or refund the purchase price thereof, and such action on the part of Motorola shall be the full extent of Motorola's liability hereunder.

This warranty is void if:

- a. the product is used in other than its normal and customary manner;
- b. the product has been subject to misuse, accident, neglect or damage;
- c. unauthorized alterations or repairs have been made, or unapproved parts used in the equipment.

This warranty extends only to individual products, batteries are excluded, but carry their own separate limited warranty. Because each radio system is unique, Motorola disclaims liability for range, coverage, or operation of the system as a whole under this warranty except by a separate written agreement signed by an officer of Motorola.

Non-Motorola manufactured products are excluded from this warranty, but subject to the warranty provided by their manufacturers, a copy of which will be supplied to you on specific written request.

In order to obtain performance of this warranty, purchaser must contact its Motorola salesperson or Motorola at the address first above shown, attention Quality Assurance Department.

This warranty applies only within the United States.

EPS-27734-O

COMPUTER SOFTWARE COPYRIGHTS

The Motorola products described in this instruction manual may include copyrighted Motorola computer programs stored in semiconductor memories or other media. Laws in the United States and other countries preserve for Motorola certain exclusive rights for copyrighted computer programs, including the exclusive right to copy or reproduce in any form the copyrighted computer program. Accordingly, any copyrighted Motorola computer programs contained in the Motorola products described in this instruction manual may not be copied or reproduced in any manner without the express written permission of Motorola. Furthermore, the purchase of Motorola products shall not be deemed to grant either directly or by implication, estoppel, or otherwise, any license under the copyrights, patents or patent applications of Motorola, except for the normal non-exclusive, royalty free license to use that arises by operation of law in the sale of a product.

EPS-34440-B

68P81112E94-B



MOTOROLA INC.
 Communications
 Sector

**DIGITAL VOICE PROTECTION (DVP)
 CODE INSERTER)**
 MODELS T3010BX
 AND T3010AX

CONTENTS

<i>SECTION</i>	<i>NUMBER</i>
Commercial Warranty (Standard)	inside cover
Forewordii, iii
Performance Specificationsiv
Model Tableiv
1. DESCRIPTION	1
1.1 Introduction	1
1.2 Physical and Electrical Characteristics	1
1.3 Component Parts	1
1.4 Function	1
2. OPERATING INSTRUCTIONS	2
3. THEORY OF OPERATION	8
3.1 Introduction	8
3.2 Central Processing Unit (CPU) Board	8
3.3 Interface Board	8
3.4 Battery Block	10
4. MAINTENANCE	12
4.1 Introduction	12
4.2 Battery Replacement	12
4.3 Fuse Replacement	12
Troubleshooting ChartEEPS-32991
Circuit Board Detail and Schematic Diagram (Later Version)PEPS-42693
Circuit Board Detail and Schematic Diagram (Earlier Version)PEPS-33133
Exploded View, Electrical, and Mechanical Parts ListsPEPS-33134

©, Motorola, DVP, SYNTOR, Micor, and MX300 are trademarks of Motorola Inc.

FOREWORD

1. SCOPE OF MANUAL

This manual is intended for use by experienced technicians familiar with similar types of equipment. It contains all service information required for the equipment described and is current as of the printing date. Changes which occur after the printing date are incorporated by Instruction Manual Revisions (SMR). These SMR's are added to the manuals as the engineering changes are incorporated into the equipment.

2. MODEL AND KIT IDENTIFICATION

Motorola equipments are specifically identified by an overall model number on the nameplate. In most cases, assemblies and kits which make up the equipment also have kit model numbers stamped on them. When a production or engineering change is incorporated, the applicable schematic diagrams are updated.

3. SERVICE

Motorola's National Service Organization offers one of the finest nation-wide installation and maintenance programs available to communication equipment users. This organization includes approximately 900 autho-

rized Motorola Service Stations (MSS) located throughout the United States, each manned by one or more trained, FCC licensed technicians.

These MSS's are independently owned and operated and were selected by Motorola to service its customer. Motorola maintenance is available on either a time or material basis or on a periodic fixed-fee type arrangement.

The administrative staff of this organization consists of national, area and district service managers and district representatives, all of whom are Motorola employees with the objective to improve the service to our customers.

Should you wish to purchase a service contract for your Motorola equipment, contact your Motorola Service Representative, or write to:

National Service Manager
Motorola Communications and Electronics, Inc.
1303 E. Algonquin Road
Schaumburg, Illinois 60196

REPLACEMENT PARTS ORDERING

ORDERING INFORMATION

Motorola maintains a number of parts offices strategically-located throughout the United States. These facilities are staffed to process parts orders, identify part numbers, and otherwise assist in the maintenance and repair of Motorola Communications Sector products.

Orders for all parts *except* crystals, active filters, channel elements, and Vibrasender and Vibrasponder resonant reeds should be sent to the nearest area parts center. Orders for instruction manuals should also be sent to the area parts center.

When ordering replacement parts or equipment information, the complete identification number should be included. This applies to all components, kits, and chassis. If the component part number is not known,

the order should include the number of the chassis or kit of which it is a part, and sufficient description of the desired component to identify it.

Orders for crystals, channel elements, active filters, and reeds should be sent to the Component Product Sales & Service address listed below. Crystal and channel element orders should specify the crystal or channel element type number, crystal and carrier frequency, and the chassis model number in which the part is used.

Orders for active filters, Vibrasender and Vibrasponder resonant reeds should specify type number and frequency, should identify the owner/operator of the communications system in which these items are to be used; and should include any serial numbers stamped on the components being replaced.

COMPONENT PRODUCT SALES & SERVICE OFFICE

All Mail Orders
Motorola, Inc.
Component Product Sales & Service
P.O. Box 66191, O'Hare International Airport
Chicago, IL 60666

Correspondence
Motorola, Inc.
Component Product Sales & Service
2553 N. Edgington Street, Franklin Park, IL 60131
Tel: 312-451-1297, TWX: 910-227-0799, Telex: 433-0067

AREA PARTS OFFICES

Western Area Parts
1170 Chess Drive, Foster City, CA 94404
Tel: 415-349-8621, TWX: 910-375-3877

Pacific-Southwestern Area Parts
P.O. Box 85036, San Diego, CA 92138
Street Address:
9980 Carroll Canyon Road, San Diego, CA 92131
Tel: 619-578-8030, TWX: 910-335-1516

Gulf States Area Parts
P.O. Box 73115, 1140 Cypress Station, Houston, TX 77090
Tel: 713-537-3636, TWX: 910-881-6392

Southwestern Area Parts
P.O. Box 34290, 3320 Belt Line Road, Dallas, TX 75234
Tel: 214-620-8511, TWX: 910-860-5505

Midwest Area Parts
1313 E. Algonquin Rd., Schaumburg, IL 60196
Tel: 312-576-7430, TWX: 910-693-0869

Southeastern Area Parts
P.O. Box 368, Decatur, GA 30031
Street Address:
5096 Panola Industrial Blvd., Decatur, GA 30032
Tel: 404-987-2232, TWX: 810-766-0876

Rocky Mountain Area Parts
20 Inverness Place East, Englewood, CO 80122
Tel: 303-790-2323, TWX: 910-935-0785

East Central Area Parts
12955 Snow Road, Parma, OH 44130
Tel: 216-433-1560, TWX: 810-427-9424

Eastern Area Parts
85 Harristown Road, Glen Rock, NJ 07452
Tel: 201-447-4000, TWX: 710-988-5614

Mid-Atlantic Area Parts
7230 Parkway Drive, Hanover, MD 21076
Tel: 301-796-8763, TWX: 710-862-1941

National Accounts
Railroad, Airlines, and Telephone Sales
1313 E. Algonquin Rd., Schaumburg, IL 60196
Tel: 312-576-6512, TWX: 910-693-0869

All Canadian Orders
Motorola, Ltd., National Parts Department
3125 Steeles, Ave. E., North York, Ontario M2H 2H6
Tel: 416-499-1441, TWX: 610-491-1032,
Telex: 06-526258

National Data Services

1171 West 17th Street, Tempe, AZ 85281
Tel: 602-994-6472, TWX: 910-951-1334

All Countries Except U.S. & Canada

Motorola, Inc., International Parts Department
1313 E. Algonquin Rd., Schaumburg, IL 60196, U.S.A.
Tel: 312-576-7241, TWX: 910-693-0869
Telex: 722443, Cable: MOTOL PARTS

PERFORMANCE SPECIFICATIONS

Power Supply	7.5 V Battery (rechargeable Nickel Cadmium)	
Number of Keys	2.36 x 10 ²¹ orthogonal (unique) key variables	
Key Storage	Stores up to 8 keys in volatile electronic memory	
Key Loading Method	Manual operator entry via keypad	
Key Transfer Method	Via temporary patch cord connection to <i>DVP</i> radio	
Display	8 digit, 7 segment LED display monitors operational status and provides review of manually entered keys prior to transfer into non-recallable memory	
	Size	Weight
Key Inserter only	5.76" (146.3mm)	11.5 oz. (326g)
Key Inserter with Battery		
Light Capacity	7.23" (183.6mm)	16.7 oz. (473g)
Medium Capacity	7.59" (192.8mm)	19.3 oz. (547g)
High Capacity	9.31" (236.5mm)	25.3 oz. (717g)
Ultra-High Capacity	10.21" (259.3mm)	34.0 oz. (965g)
Average No. of Key Insert Operations*		
Medium Capacity Battery	200	
High Capacity Battery	350	

Assumes one manual programming operation plus 30 seconds "on" time per key insertion.

MODEL COMPLEMENT TABLE FOR MODEL T3010AX DIGITAL VOICE PROTECTION CODE INSERTER

Item	Description
NLN8834C	Battery
TKN8209A	Portable Cable
TKN8210A	<i>Micor</i> Cable
TKN8229A	<i>SYNTOR</i> Cable
TLN2437A	<i>DVP</i> Inserter
NLN7314A	Back Cover
TRN4834A	Interface Board
TRN4835A	CPU Board
TRN4839A	Cover Front
TRN4934A	Hardware Kit
TRN4974A	Read Only Memory (ROM)
TRN6777B	Vulcan Hybrid
TLN2379A	Flex Kit and Frame
TRN4837A	Flex Kit
TRN4838A	Frame Kit
TRN5000A	Frame Hardware
TRN5300A	<i>DVP</i> Label

MODEL COMPLEMENT TABLE FOR MODEL T3010BX DIGITAL VOICE PROTECTION CODE INSERTER

Item	Description
NLN8834C	Battery
NLN7314A	Back Cover
TLN2437B	<i>DVP</i> Inserter
TRN4834A	Interface Board
TRN4835A	CPU Board
TRN4839A	Cover Front
TRN4934A	Hardware Kit
TRN4974A	Read Only Memory (ROM)
TRN6777B	Vulcan Hybrid
TLN2379A	Flex Kit and Frame
TRN4837A	Flex Kit
TRN4838A	Frame Kit
TRN5000A	Frame Hardware
TRN5300A	<i>DVP</i> Label

OPTION TABLE FOR MODEL T3010BX KEY VARIABLE LOADER CABLE KITS

Item	Description
TKN8209B	MX Cable
TKN8210B	<i>Micor</i> Cable
TKN8229B	<i>SYNTOR</i> Cable
TKN8351A	Expo Cable

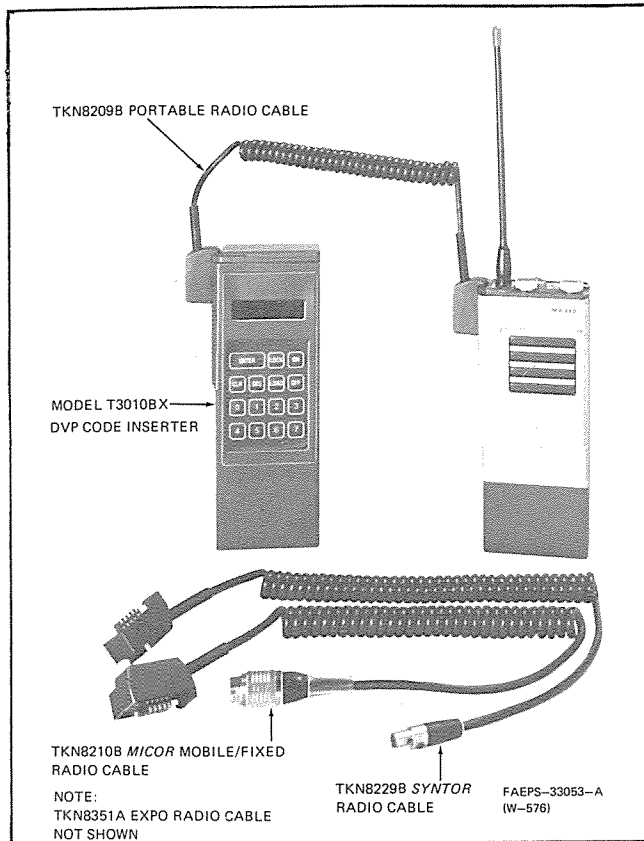

Figure 1. DVP Code Inserter Connected to Portable Radio

1. DESCRIPTION

1.1 INTRODUCTION

The Motorola Models T3010AX and T3010BX Digital Voice Protection (DVP) Code Inserters are hand held electronic coding devices used to encode DVP equipped radios. The operator manually programs the selected key into the code inserter through an 8-digit keypad on the inserter. Pressing the PUSH-TO-TRANSFER switch on the inserter causes the key to be transferred to the radio, via a cable, as shown in Figure 1.

1.2 PHYSICAL AND ELECTRICAL CHARACTERISTICS

1.2.1 The code inserter is a slim hand held unit constructed of high impact polycarbonate plastic. It is designed for field use. Its weight and size are determined by the battery selected. See performance specifications in this manual for exact size and weight. The loader uses standard MX300 series portable batteries, chargers, and leather carrying cases. (See Figure 2.)

1.2.2 The Motorola MC6802 microprocessor based circuitry is powered by a nominal 7.5 V battery. The microprocessor contains 128 bytes of "on board" RAM for temporary variable storage during program execution; external 256 x 4 RAM is used for storage of key variables and locks. Any of the possible 2.36×10^{21} keys can be chosen by the user. The 4K x 8 ROM contains the operational program which controls the electronics of the code inserter.

1.2.3 To conserve battery power, the code inserter "times out" and shuts itself off if no usage occurs within 30 seconds in the radio coding mode and 1.5 minutes in the loader entry mode. Prior to "timing out" or powering down, the inserter emits a warning tone to alert the user. CMOS memory circuits are still provided power, and their content is not altered.

1.2.4 When exchanging batteries, the code inserter will retain all previously stored information; the memory circuits remain unchanged for at least 30 seconds.

1.3 COMPONENT PARTS

1.3.1 The Code Inserter consists of three main parts: 1) electronics unit, 2) battery pack, and 3) interface cables. The electronics unit is divided into the CPU circuit board, interface circuit board, flex circuit, frame, and case.

1.3.2 The CPU circuit board includes a Motorola MC6802 microprocessor, random access memory (RAM), read only memory (ROM), and a peripheral interface adapter (PIA). A unique inserter program is permanently stored in the ROM. The PIA interfaces the CPU circuit board to the keypad, display, encrypt hybrid, and external radio.

1.3.3 The interface circuit board contains the circuitry for the power regulator, low battery detect circuit, data output display and driver, and data entry keypad.

1.3.4 The flex circuit and frame kit contain the press-to-transfer switch and cable connector for transfer of DVP keys to a radio.

1.4 FUNCTION

1.4.1 The code inserter functions by accepting a selected key, storing the key, and upon command, transferring the key to program the radio. The operator chooses a key and manually enters it into the inserter through the keypad. Keys are loaded one at a time, up to a maximum of eight. The key can be reviewed before entering it into the memory circuitry. For security purposes, the key cannot be recalled once entered into memory.

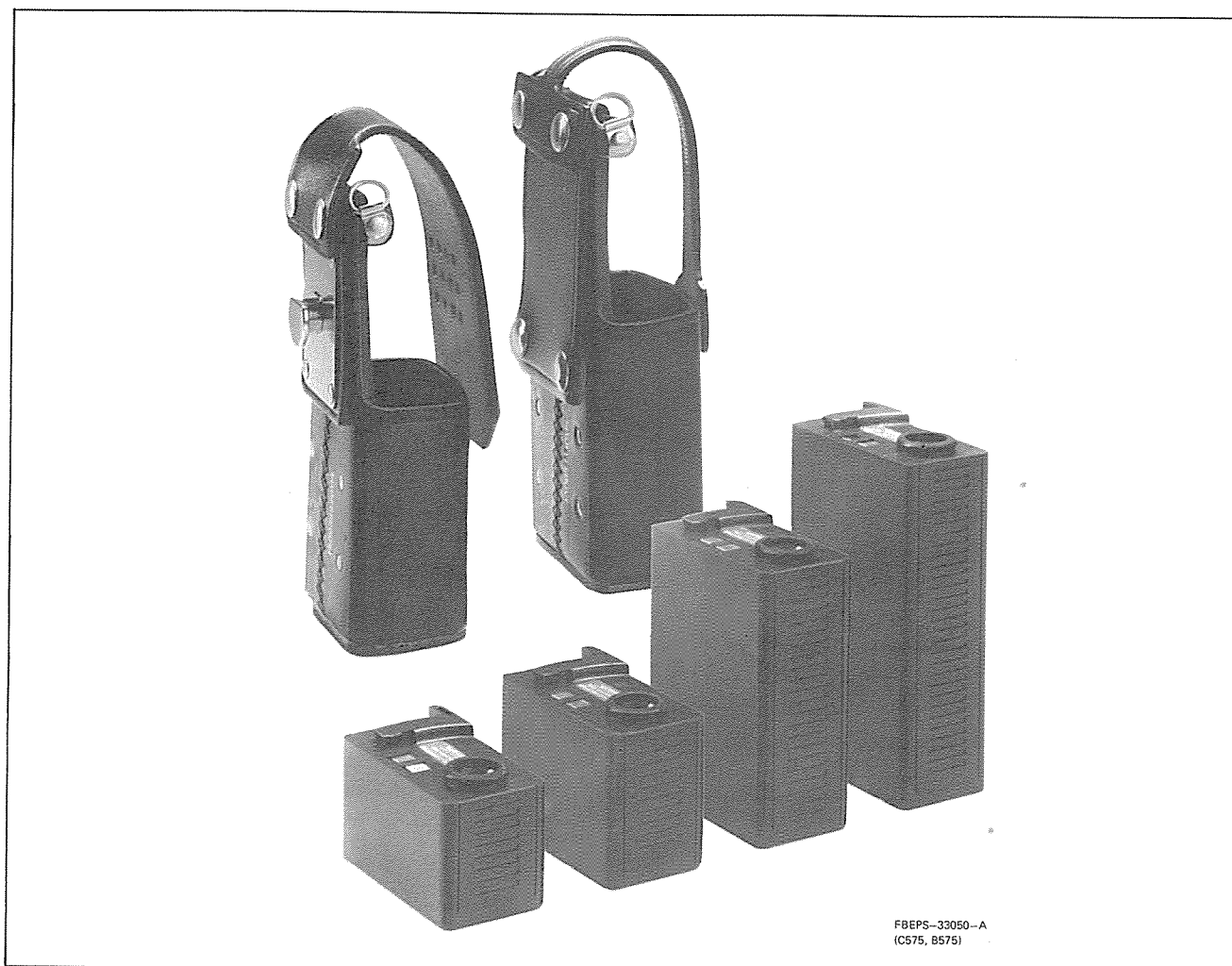

Figure 2. MX300 Series Portable Radio Batteries and Leather Carrying Cases

1.4.2 When a radio is to be programmed with a *DVP* key stored in the inserter, the operator presses a switch on the side of the inserter. The key is transferred to the radio through an interconnecting cable. An audio signal, originating from the inserter and heard through the radio's speaker, verifies that the transfer was made. When the code inserter is turned off and at a later time turned on, it will be ready to transfer the previously entered key.

1.4.3 As a feature, the keypad can be electronically locked. A combination code is loaded into memory. The keypad then becomes inoperable until the proper sequence is followed to "unlock" the keypad. See the Operating Instructions section of this manual for details.

2. OPERATING INSTRUCTIONS

The T3010AX and T3010BX *DVP* (Digital Voice Protection) Code Inserters are handheld portable units used to program *DVP* radios in the field. The *DVP* code

inserter can store up to eight distinct keys. Each key consists of 24 octal digits (four sequences of six characters). Keys are manually loaded, one at a time, and can then be selected and transferred to a *DVP* radio. Keys cannot be recalled to the inserter display once they have been initially entered into memory.

The multiple key storage capability allows a code loader to service several different user groups who operate on different keys. Because the keys cannot be recalled to the display after being entered into memory, one person may program the inserter, then allow other users to enter the keys without disclosing their identity.

IMPORTANT

The Motorola R1012C *DVP* Test Set can generate a test key identical to one which can be loaded with the T3010AX and T3010BX Code Inserters. Use of this key for normal system operation should be avoided to ensure communications security. The test key is
70707070707070707070707070707070 (enter the number 70 twelve times).

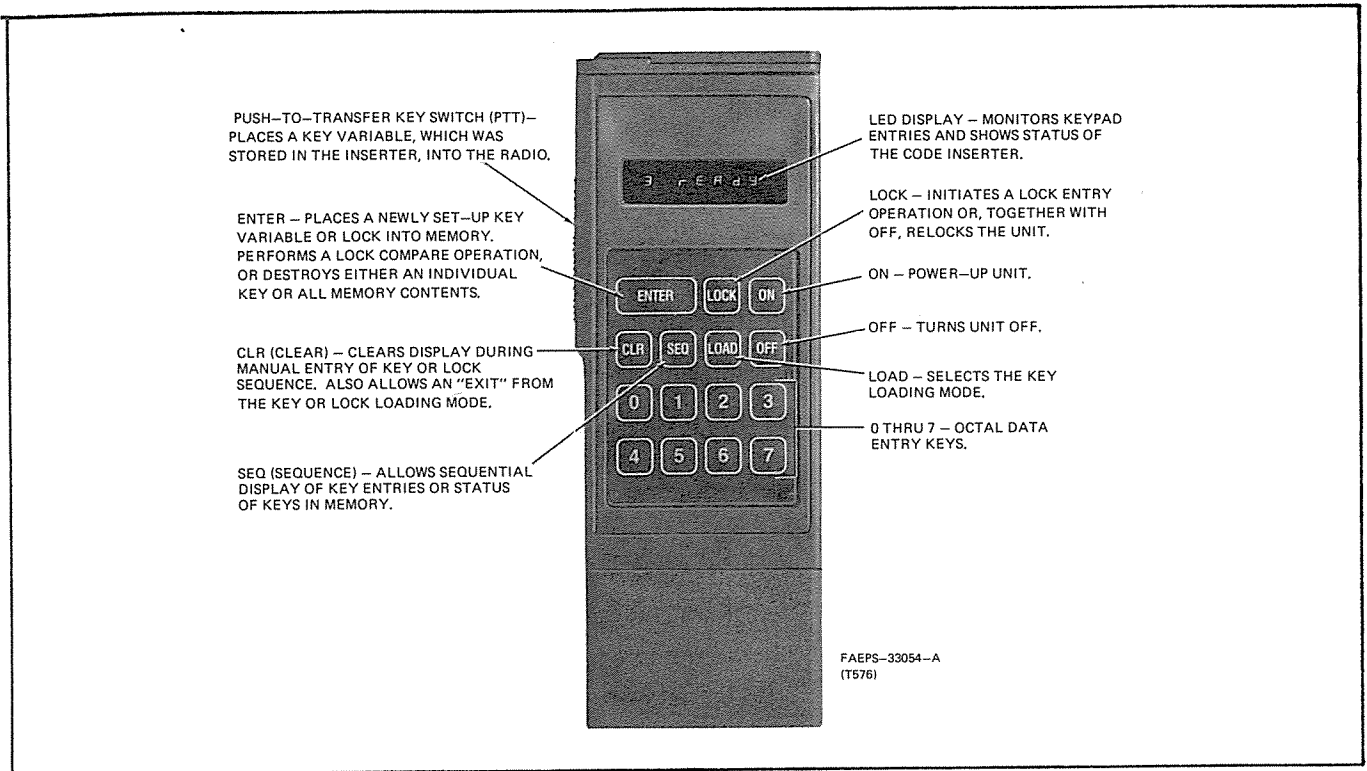
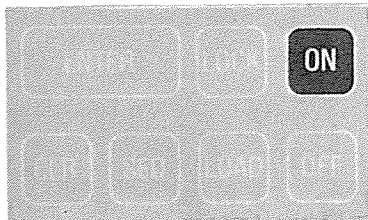

Figure 3. DVP Code Inserter Control and Indicators

TO TURN UNIT ON OR OFF



Press ON to turn unit ON.

Display indicates "READY", "ERASED", or "LO CHARGE". If LO CHARGE is displayed, turn the unit off and recharge or replace the battery.

NOTE

The last used memory location number (0-7) will also be displayed.

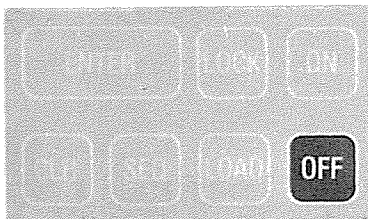

Press OFF to turn unit off.

If the unit's internal memory has been disturbed since the last power up, the display will read "ALL ERASED".

Display goes blank.

NOTE

If no key entry is made for 30 seconds after the unit is turned on, it will automatically shut down to conserve battery power. Whenever a prompt is present on the display, the unit will remain on for 90 seconds after the last keystroke before automatic shutdown. In either case, simply press ON button to turn power back on.

TO LOAD A KEY

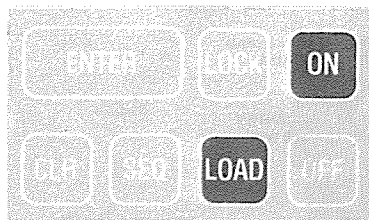

Press ON to turn unit on.

Display reads "READ" "ERASED" and indicates used memory location (0-7).

Press LOAD to begin loading.
Group sequence number

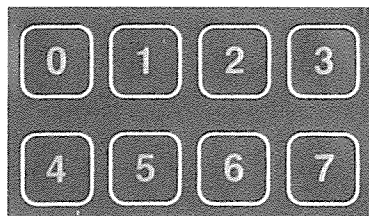

Depress any button 0-7 to select desired key memory location, or use the SEQUENCE key to select the next location. The group sequence number will be 1.

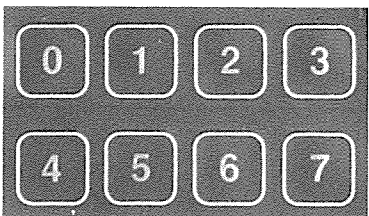
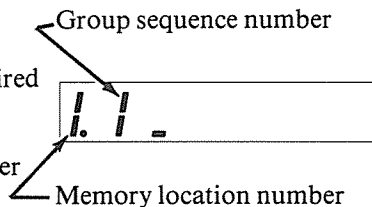

Enter first six digits of the key.

Display shows each digit as it is entered.



Enter next six digits of the key.

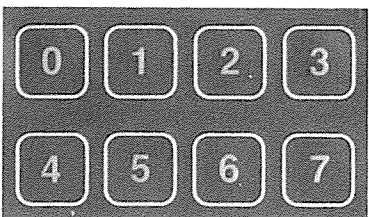
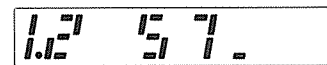

Enter next six digits of the key.

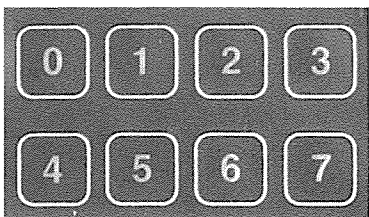
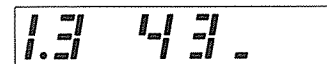

Enter last six digits of the key. The very last digit **MUST** be 0, 1, 2, or 3.

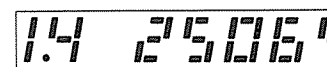

NOTE

A flashing "E" indicates an improper last digit. A period appears after a correct last digit is entered.

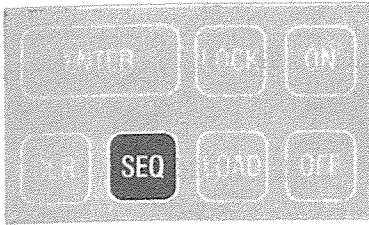

Verify proper entry of each group of six digits using SEQ button to step through each group. If any errors are found, make corrections using the Correcting An Error procedures before continuing.

Group sequence number changes each time SEQ button is depressed. Each group of six digits appears on display, one group at a time.

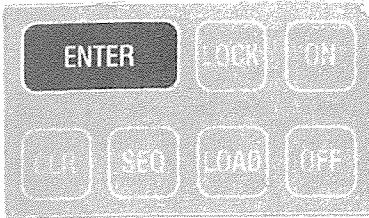

Depress ENTER button to enter the key in the selected memory location. The key can NOT be displayed or corrected after this step.



NOTE

The entire load procedure can be repeated up to 8 times using different memory locations.

**CORRECTING AN ERROR
(USE ONLY BEFORE PRESSING ENTER)**

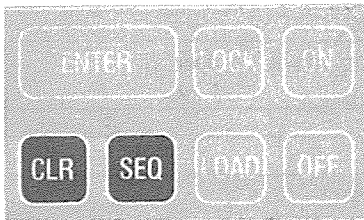

Use SEQ button to bring the desired group on the display. Depress CLR button.

The six key digits on the display are erased.

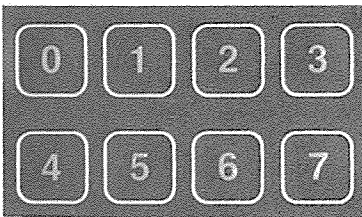

Re-enter the six key digits correcting any previous wrong entry.

Display shows each digit entered.

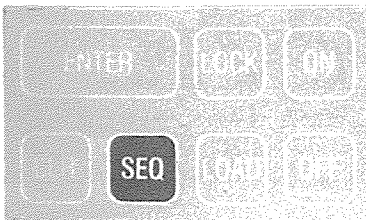

Use SEQ button to verify proper key entry for all key groups.

Each six digit key group is displayed in sequence.

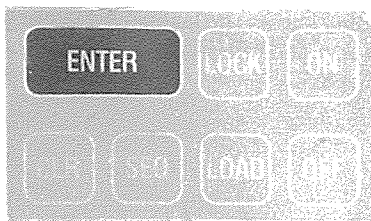

Depress ENTER button to enter the key in the selected memory location.

Display shows the selected memory location and "READY".



TO LOCK THE INSERTER
(No Previous Keys Or Lock May Be Present)

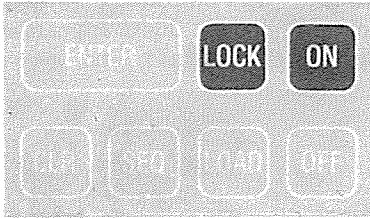

Press ON to turn unit on.

Press LOCK button.

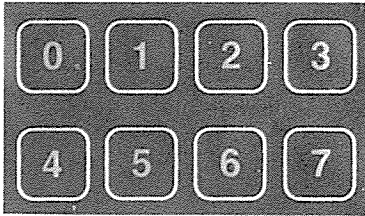
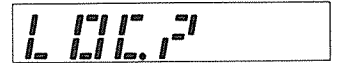

Enter any number up to 6 digits.



IMPORTANT

Remember the sequence and the digits entered in order to unlock the unit.

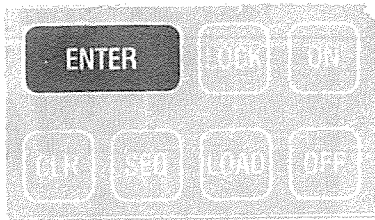

Press ENTER button.

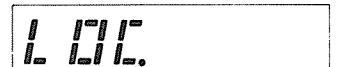

The inserter is now locked. The unit will not accept a key entry nor can it be used to transfer a key into a radio until it is unlocked.

TO UNLOCK THE INSERTER

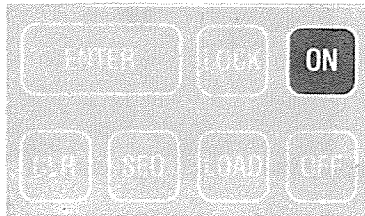

Press ON to turn the unit on.

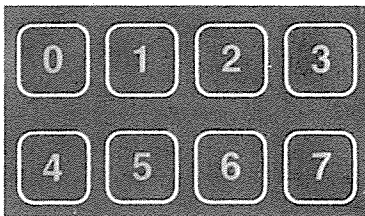
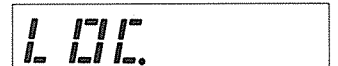

Enter the same digits and in the same sequence used to lock the unit.

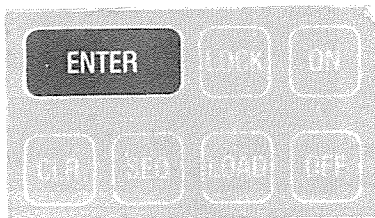
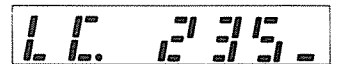

Press the ENTER button.

Display shows the last used memory location and "READY" or "ERASED".

The unit is now unlocked and will operate normally.

NOTE

Again depressing LOCK and then OFF will relock the inserter.

TO DESTROY AN EXISTING KEY

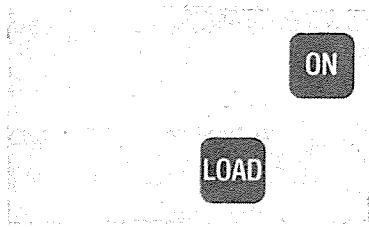

Press ON to turn unit on.

LOAD.

Press LOAD key.

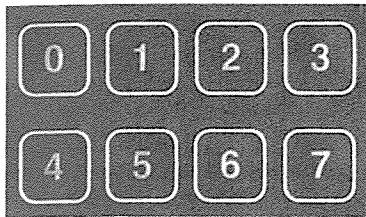

Select memory location to be destroyed by entering desired location number 0-7, or use SEQ key.

1.1.

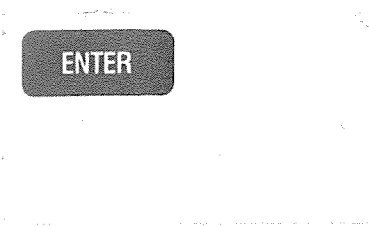

Press ENTER key.

1 ErASEd

TO DESTROY ALL EXISTING KEYS

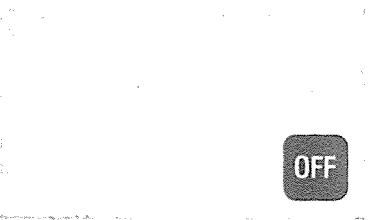

Press OFF to turn unit OFF.

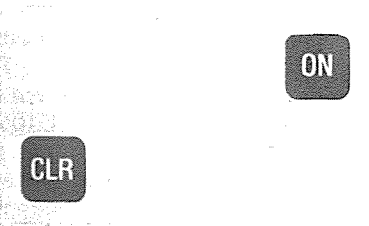

Press CLR key and while holding CLR key depressed, press ON.

All ErASEd



Press the ENTER button.

All ErASEd

TRANSFERRING A KEY INTO A RADIO

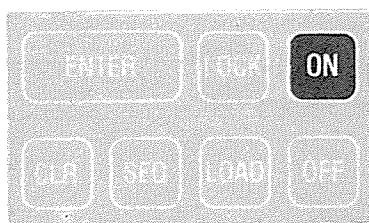

Press ON button to turn unit on.

Display shows the last used memory location and "READY" or "ERASED".



Select desired key memory location by depressing key 0-7 or use SEQ key.



Connect appropriate cable between inserter and radio.



Press PUSH TO TRANSFER switch on left side of inserter to initiate key transfer.

If the key is transferred properly, a one second verification tone is heard in the radio speaker.

ALTERNATE METHOD OF TRANSFERRING A KEY TO A RADIO

This method is used only for transferring the previously transferred key into another radio. Connect the appropriate cable between the inserter and the radio. Then, depress the PUSH TO TRANSFER button on the left hand side of the inserter. The inserter will turn on, transfer the key, and display "BEEP?". If the key is transferred properly, a one second tone is heard in the radio speaker.

3. THEORY OF OPERATION

3.1 INTRODUCTION

(Refer to Block and Schematic Diagrams.)

This section of the instruction manual covers the theory of operation for the T3010AX and T3010BX DVP Code Inserters. Most of the electronic circuitry is mounted on two circuit boards: Central Processing Unit (CPU) Board and Interface Board. The Power Control/Flex circuit electronically interconnects the Interface Board to the signaling output plug and the Battery Block. A general discussion of these items is presented in the following paragraphs. Some discussions go into greater detail to familiarize the reader with unique applications.

3.2 CENTRAL PROCESSING UNIT (CPU) BOARD

The Central Processing Unit (CPU) Board contains a microcomputer. The central processing unit (U101) is a Motorola MC6802 with 128 bytes of internal

random access memory (RAM) and an external 3.84 MHz time base. The read only memory (U103) is 4K x 8 and is used for program storage. The random access memory (U104) is 256 x 4 and is continuously powered to retain keystroke information. The peripheral interface adapter (U102) provides system input/output for the CPU board. An AND gate (U105) and amplifier (Q101) provide an audio tone output for each keystroke, time-out warning, or the "All erase" state.

3.3 INTERFACE BOARD

3.3.1 General

The interface board contains the peripheral circuitry for operator interface. The data entry keypad (S202) allows the operator to enter selected data. The data output display (DS201) shows the operator what is being entered, prompts the operator for entries, and indicates results of functions being performed. K

loading information is transferred through P301. The power regulator (Q202 thru Q206) and low battery detect circuitry are also located on this board.

3.3.2 Data Entry

The data entry keypad (S202) is the means by which the operator enters selected keystroke information into memory. The keypad is scanned by 3 to 8 decoder U203. The PIA sequentially presents an octal number to the three input pins (A, B, and C) of U203. All eight possibilities are tried with the low order digit and function lines enabled (MUX U202 pins 9 and 10 logic low). The high order function line is used only to scan the model finder (S201) matrix. Model finding is performed only on power-up to determine the model and output bit rate. When a key closure of sufficient duration is detected by a low output from buffer U205C or U205B, the microprocessor causes the appropriate internal machine state and display changes to occur.

3.3.3 Data Display

The LED driver (U201) is self-scanning and is only written to by the microcomputer system when a need for updating exists. When an update occurs, the WRITE line of U201 goes to a logic low once for a control sequence and then eight times for the digit information. Display driver pins A thru G and DP are segment drivers, and pins DS0 thru DS7 are digit drivers. The LED display is common cathode type.

3.3.4 Data Output

3.3.4.1 A cable interconnects the data output plug (P301) and the radio to be encoded. The interconnect cable transfers the following signals:

- KEY — A binary data sequence which is modulo two summed with a stream of encrypted or plain text in the radio's encrypt/decrypt module to produce the desired signal.
- KEY INSERT DATA — A data stream which provides RAM addresses for the key and synchronization information for the clock and data regeneration circuitry in the radio. Encrypted verification tone and idle pattern are also sent on this line for operator verification of the correct key load. This signal is often superimposed on the discriminator line in the radio.
- \overline{WE} — write enable (complement). An active low signal which enables a key load into the radio.
- KEY INSERT GROUND — Used when KEY INSERT DATA is not superimposed on the discriminator. This signal switches the source of the radio's data limiter input from the discriminator to the inserter.
- GROUND — Common line between the inserter unit and the radio.

3.3.4.2 The signaling scheme for transfer of data to an external radio is shown in Figure 4. When the push-to transfer switch (S301) is depressed, a half clock rate signal (EOM) appears on the KEY INSERT DATA line for 1000 bit clocks. This ensures clock sync in the radio. After 1000 bits, the \overline{WE} line goes logic low for 137 cycles during which key bits are loaded into the encrypt module of the radio. KEY INSERT DATA provides addresses for the key bits. After the \overline{WE} returns to a logic high, 600 cycles of encrypted idle pattern followed by 12000 cycles of verification tone are sent; then 1000 bits of END OF MESSAGE (EOM) are sent to squelch the radio. When the inserter is not executing a load sequence, the KEY, \overline{WE} , and KEY INSERT DATA lines are in a high impedance state.

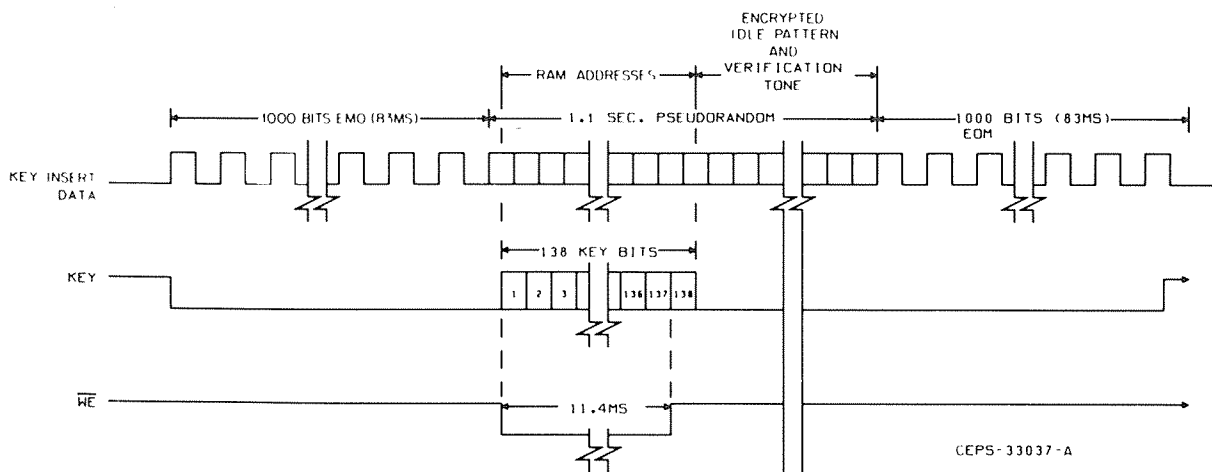

Figure 4. Signaling Scheme for Transfer of Data

3.3.5 Power Regulator

3.3.5.1 The power regulator provides the operating voltage for the CPU and interface boards. The regulator formed by Q203, Q204, and Q206 produces a VCC of 5 volts. The regulator is enabled by current injection at the base of Q204. In the "OFF" state, series pass transistor Q203 is cut off.

3.3.5.2 The power on-sequence operates as follows. Depressing either the ON or push-to-transfer (PTT) switch will saturate Q205 for approximately two time constants of the base timing circuit R224 and C206. Since POWER HOLD from PIA port CB2 is low, the collector of Q205 will be low also, providing both a CPU reset and a regulator enabling path thru power startup transistor Q202. When its base timing circuit allows the collector of Q205 to return high, the CPU begins program execution. The software module that the reset vector points to causes the POWER HOLD signal to go high. This high enables the regulator on a long term basis, but disallows any further CPU resets.

3.3.5.3 Power-down is accomplished by removing the POWER HOLD signal after the system has finished the necessary housekeeping tasks. The ALWAYS POWER voltage is provided by the power regulator when the unit is on and by the Zener network (R217 and VR201) when the unit is off. ALWAYS

POWER provides supply voltage to U104 for retention of stored keys and to U202 and U205 for putting the radio programming lines in a high impedance state when off.

3.3.6 Low Battery Detect

Low charge detection is an interrupt driven event. The interrupt request signal is produced by an FET op amp (U204) and resistor bias network (R201 thru R204) whenever the battery voltage drops below approximately 6.2 volts. Software operation is such that the user may elect to clear the unit of the low power indication and load additional radios. The battery discharge characteristic is very steep in this operating region; only very limited additional operation should be attempted.

CAUTION

Continued operation with low battery charge may destroy stored key data.

3.4 BATTERY BLOCK

The battery (BT401) is a nickel-cadmium unit. Fully charged, it measures a nominal 7.5 volts. At end-of-life, the voltage will be under 6 volts. A mercury battery can also be used. Its open circuit voltage is between 10 and 11 volts.

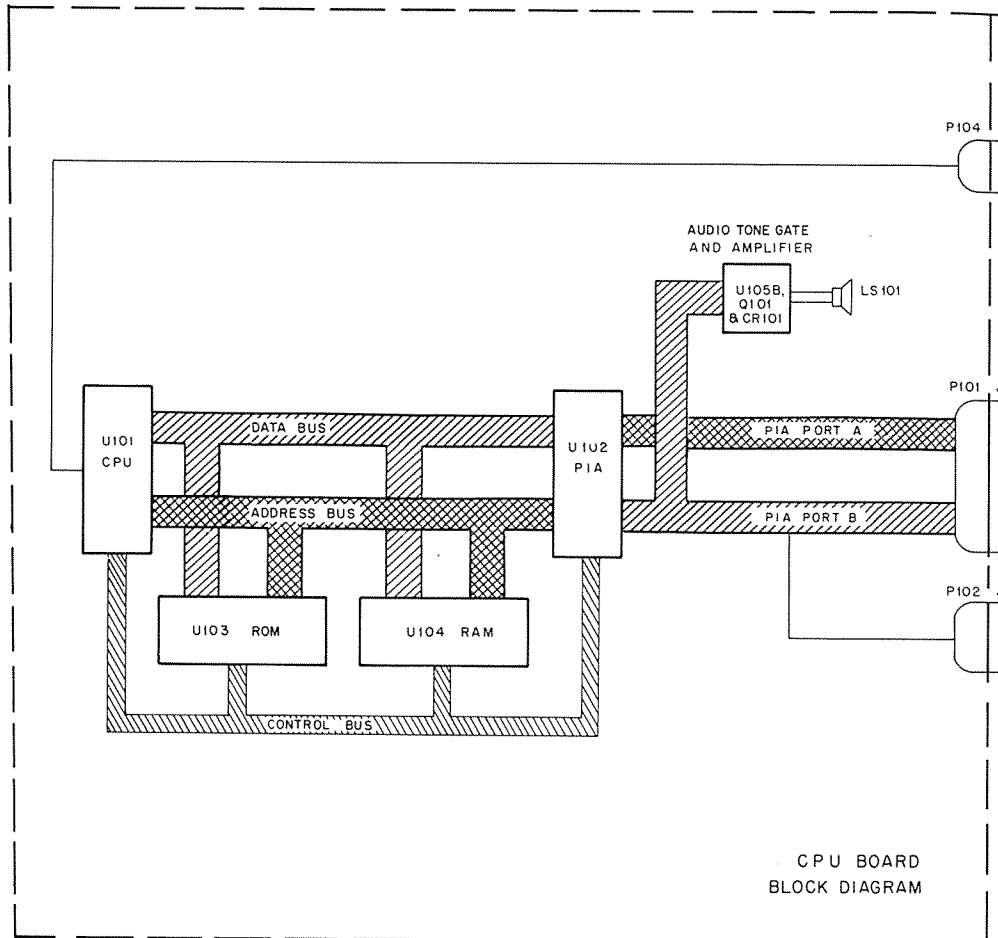
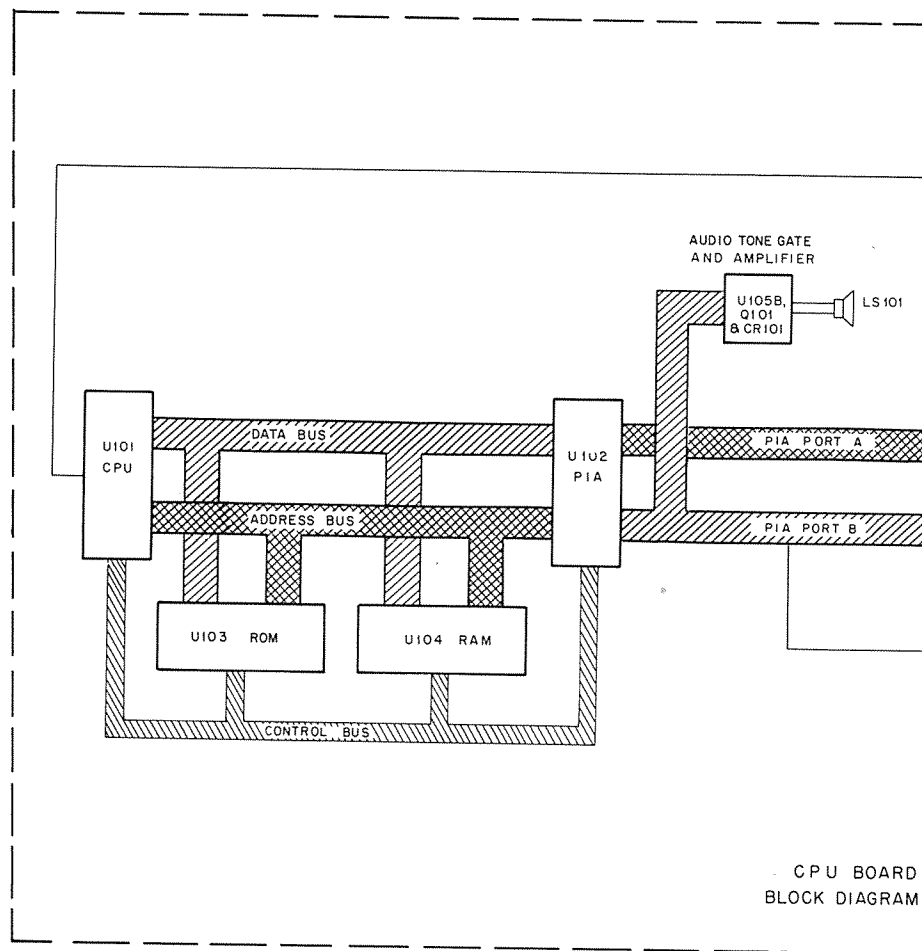

Figure 5. Block .

ention
g the
when

Driven
by an
(R201
below
h that
er in-
attery
ating
ld be

. Ful-
id-of-
attery
en 10



CPU BOARD
BLOCK DIAGRAM

Figure 5.

A

A

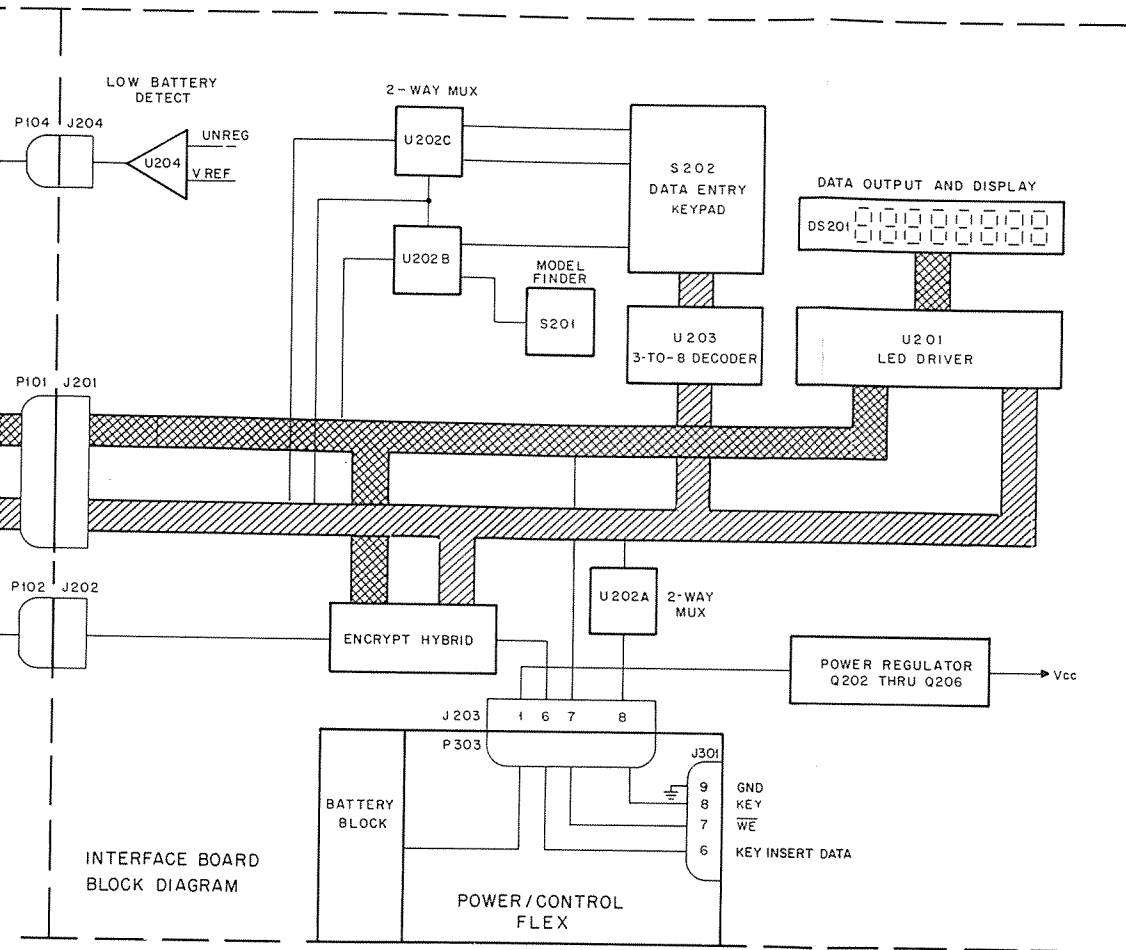

DEPS-33039-A

Block Diagram

4. MAINTENANCE

4.1 INTRODUCTION

This section of the instruction manual assists the user with maintenance and repair. In the following sections, battery and fuse replacements are described. Also included is a troubleshooting chart to assist the user in a more detailed check. For service beyond the checks listed on the chart, it is recommended that the user return the unit to a Motorola service center. See the foreword for service center information.

4.2 BATTERY REPLACEMENT

Step 1. Turn the *DVP* code inserter off.

Step 2. Hold the *DVP* code inserter in the left hand and press the battery release with the left thumb. (See Figure 6.)

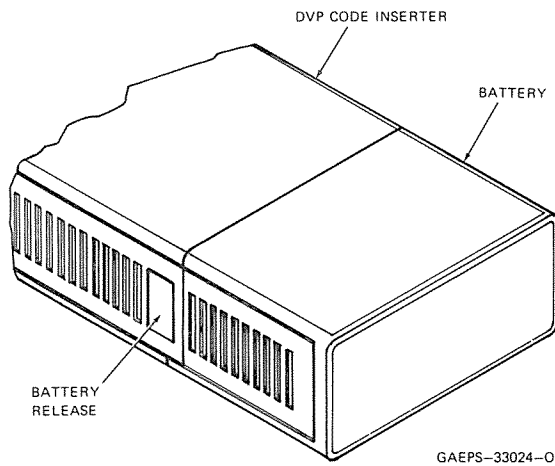

Figure 6. Battery Release

Step 3. While holding the battery release depressed, rotate the battery counterclockwise as illustrated. (See Figure 7.)

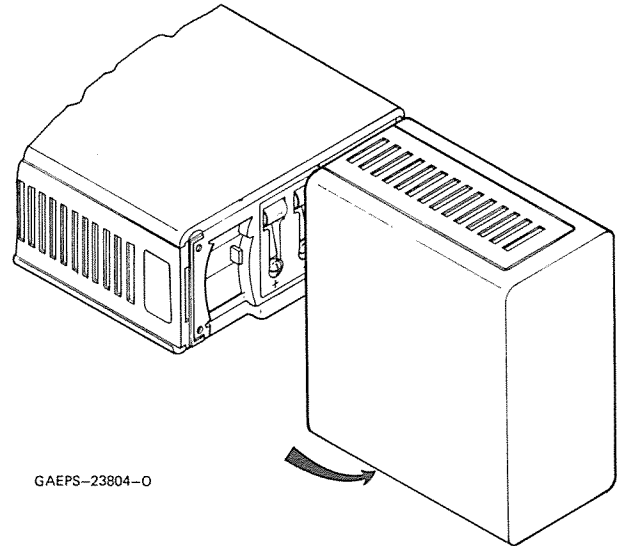

Figure 7. Battery Disengagement

Step 4. Rotate the battery about 180 degrees, until the cam lock is clear, and remove the battery from the *DVP* code inserter. (See Figure 8.)

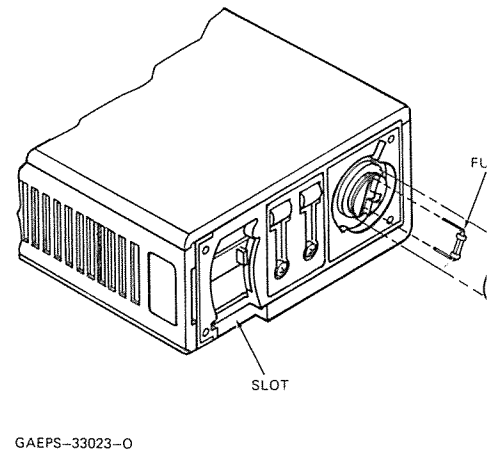

Figure 8. Battery Removal/Fuse Replacement

5. To replace the battery, reverse the procedure. Engage the cam lock, then rotate the battery clockwise until it latches in the proper position. Be sure the battery engages the slot on the bottom of the *DVP* inserter.

NOTE

Memory contents will be retained if the battery is replaced in less than 30 seconds.

FUSE REPLACEMENT

1. Remove the battery as described in the Battery Replacement procedures.
2. Unscrew the fuse cap and remove the fuse.
3. Replace the fuse with a new one and replace the fuse cap making sure it is screwed on securely.
4. Reinstall the battery as described in the Battery Replacement procedure.

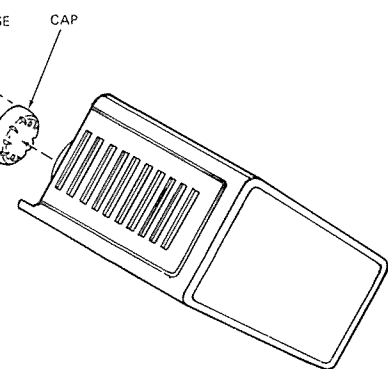

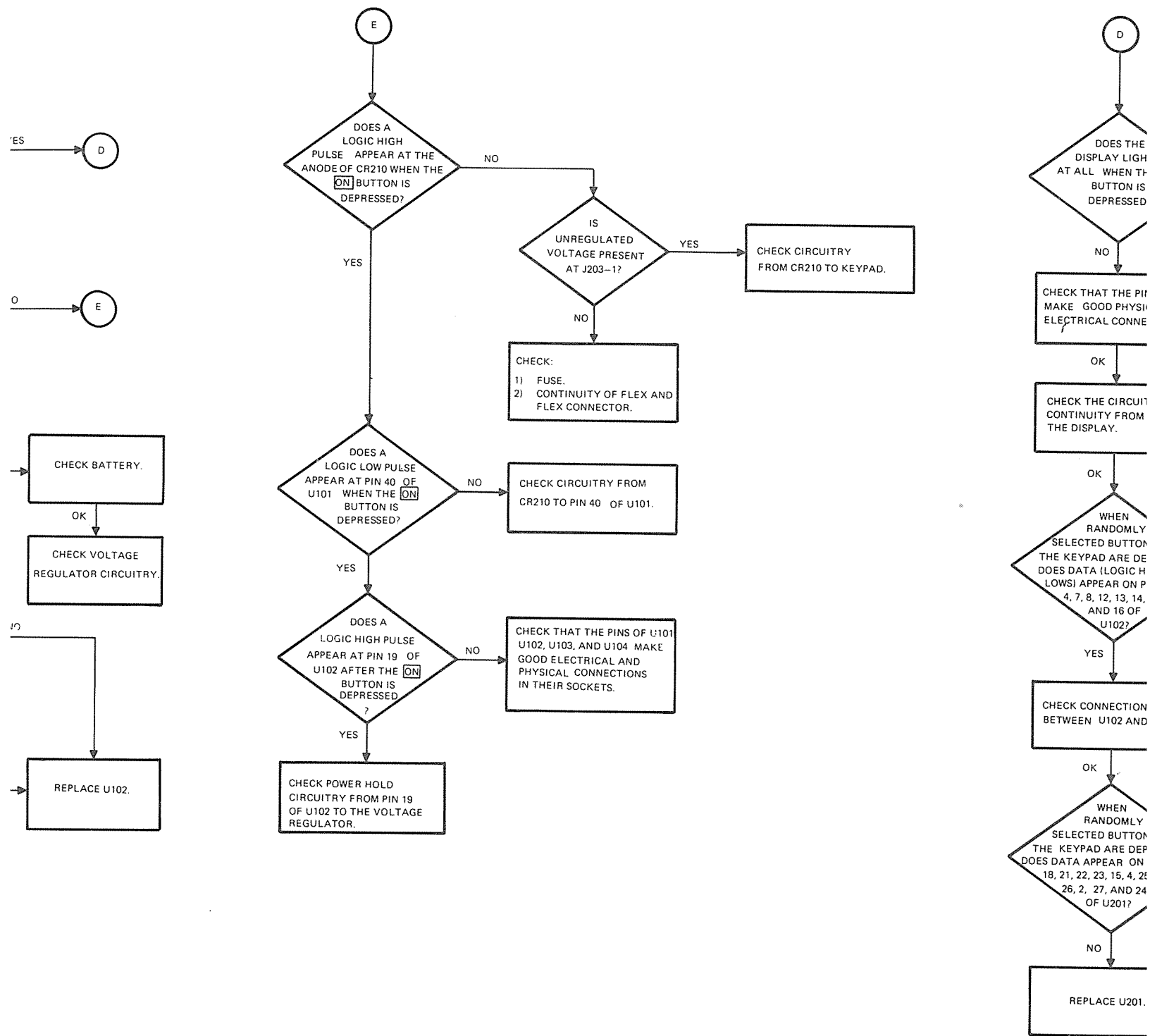

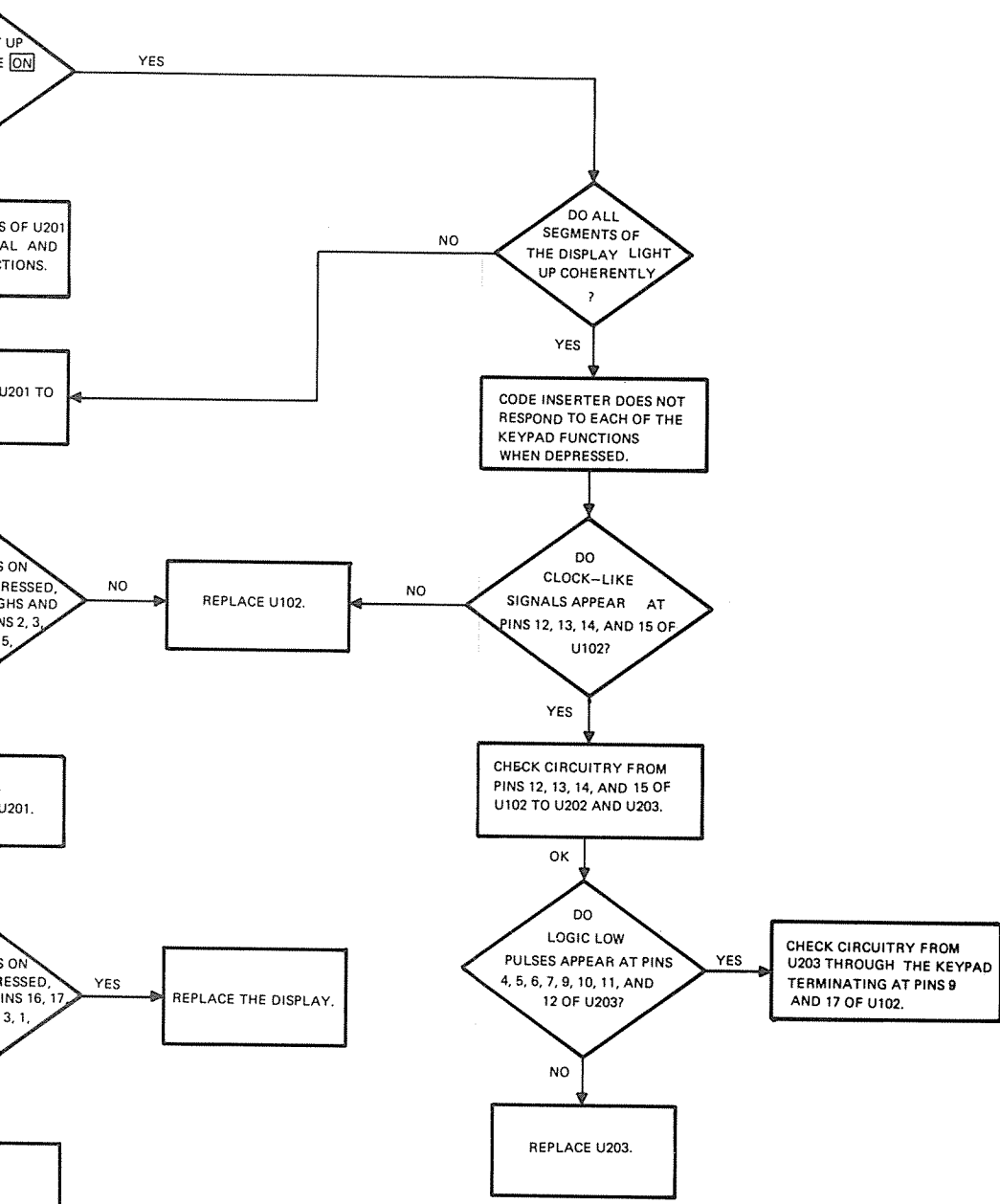

EEPS-32991-A

*DVP Code Inserter
Troubleshooting Chart
Motorola No. EEPS-32991-A
1/18/82- UP*

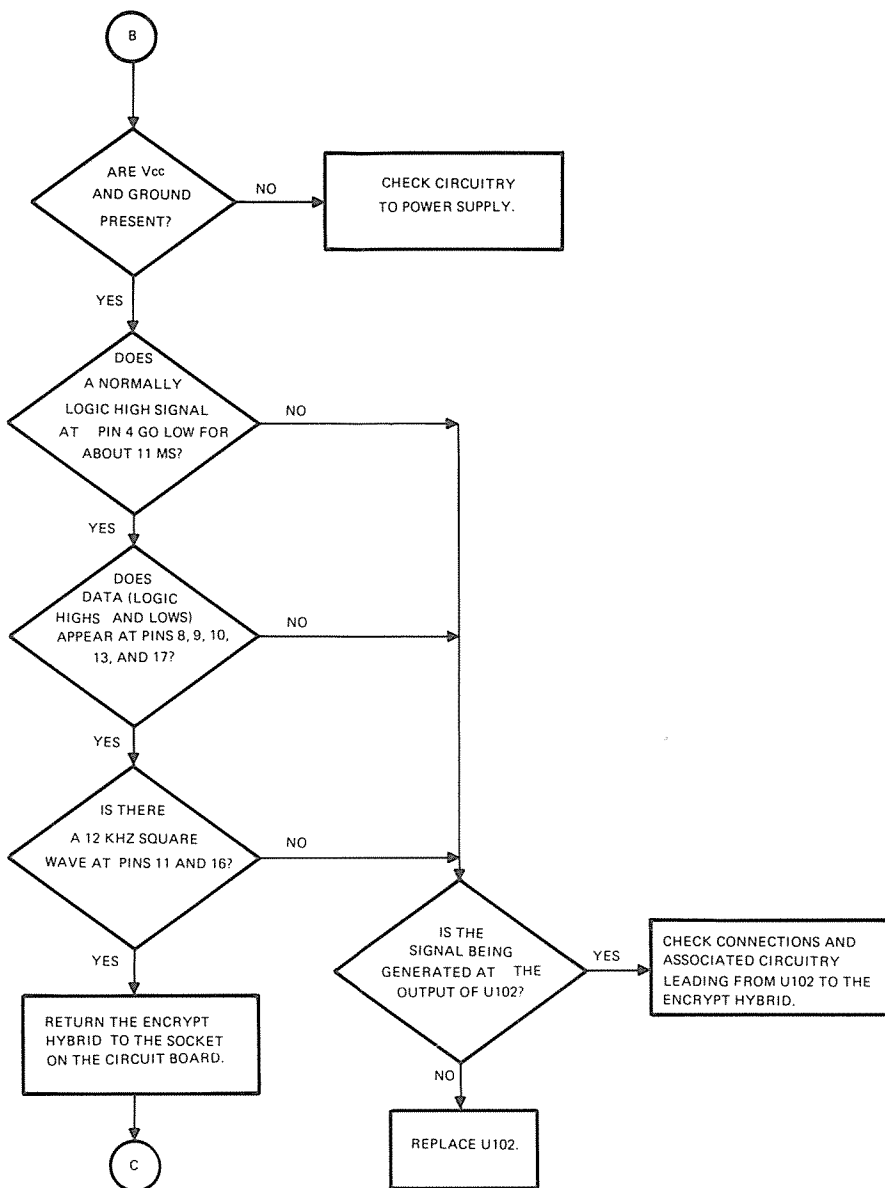
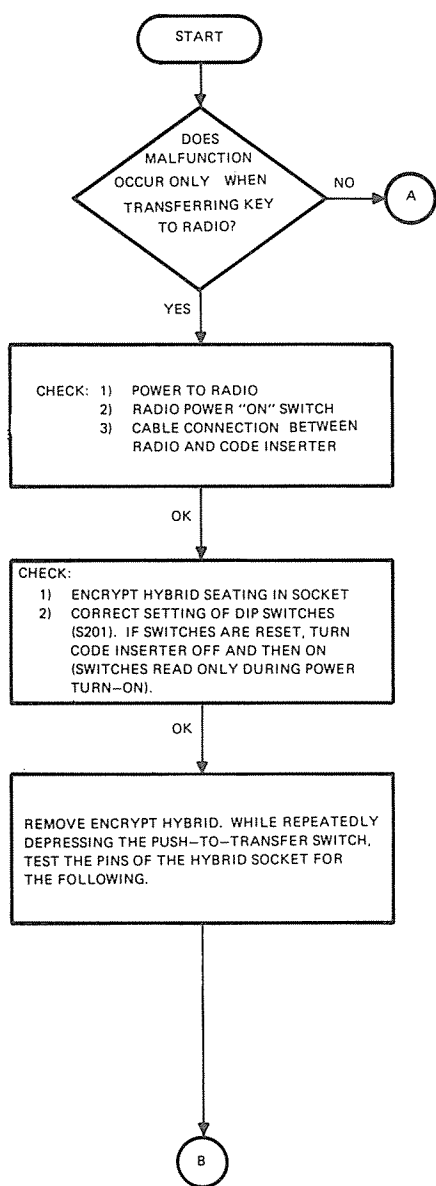

DIS
CO
THI
CO

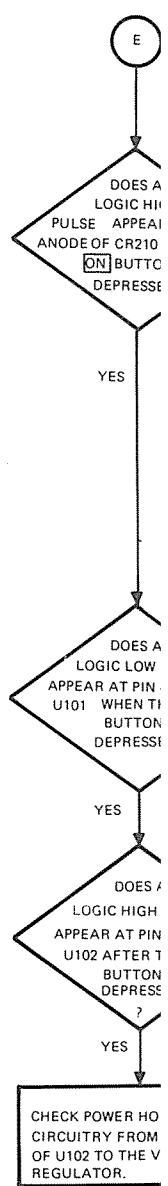
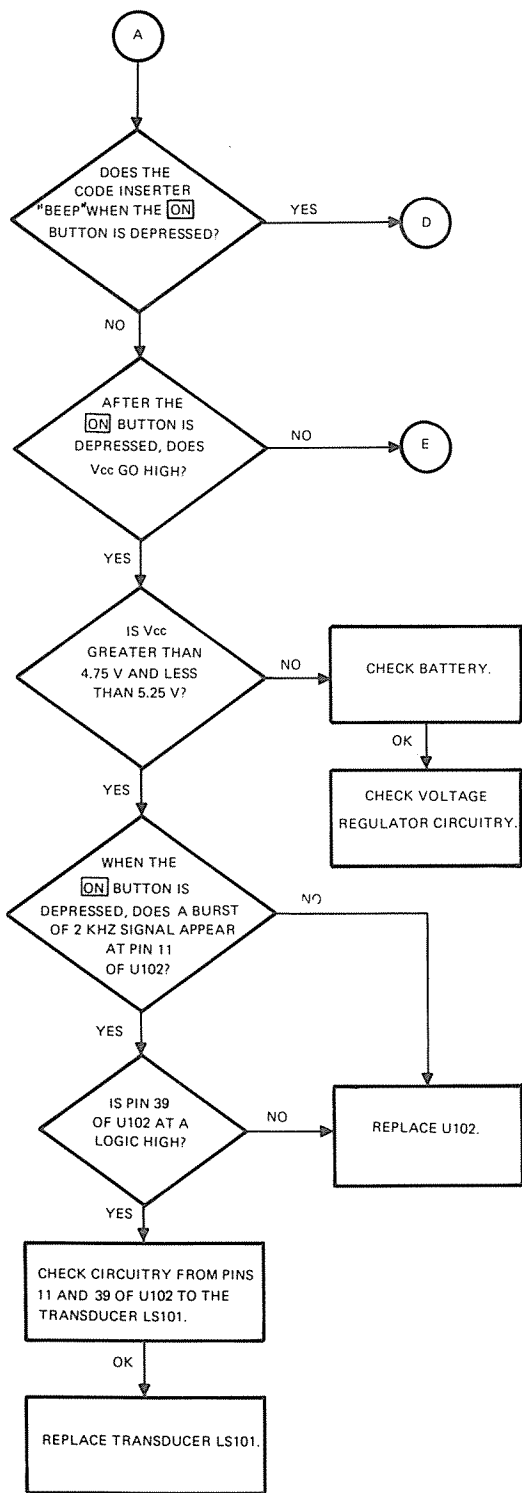
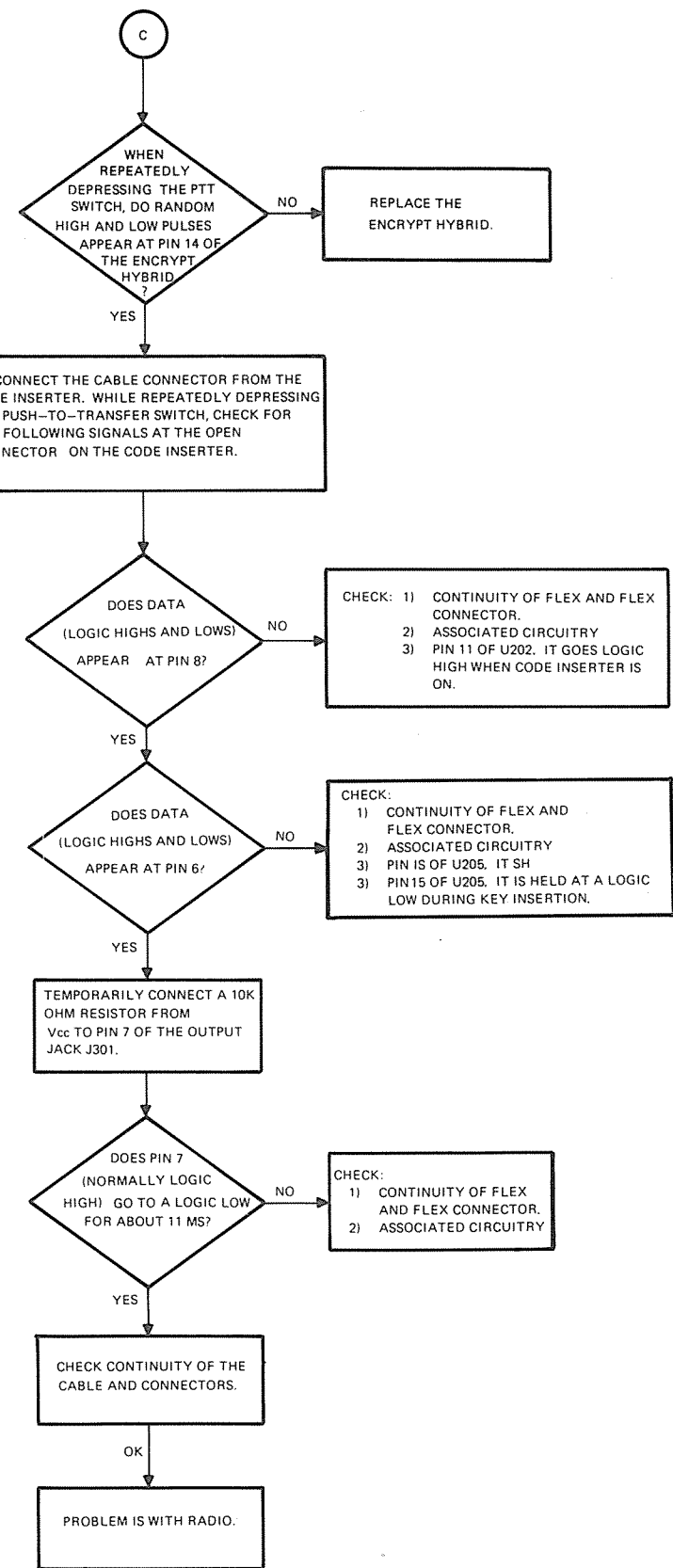

LATER VERSION CPU CIRCUIT BOARD

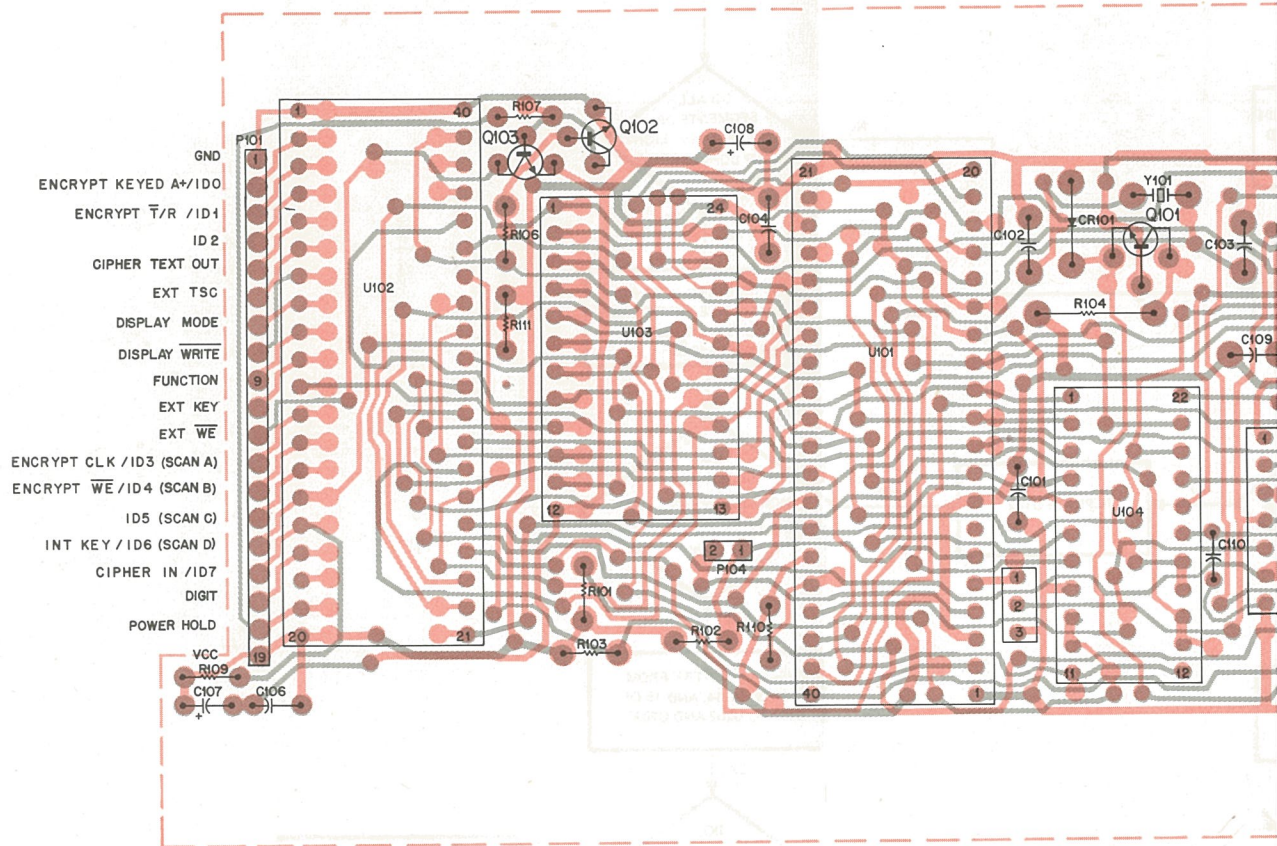

SHOWN FROM COMPONENT SIDE

SOLDER SIDE ● BD-
COMPONENT SIDE ● BD-
OL-

LATER VERSION

DVP Code Inserter
Schematic Diagram and Circuit Board Detail
 Motorola No. PEPS-42693-O
 (Sheet 1 of 2)
 12/5/85-

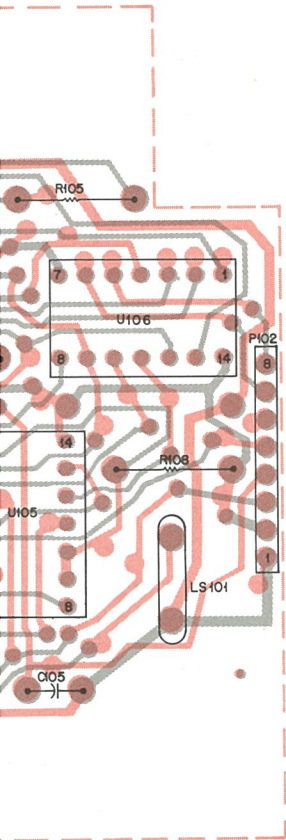

ENCRYPT CLK
 ENCRYPT CLK
 BUFFERED POWER HOLD
 ALWAYS POWER
 CPU RESET
 VCC
 GND

TRANSISTOR BASE DETAIL (TOP VIEW)



M9648

DEPS - 42686 - 0
 DEPS - 42687 - 0
 DEPS - 42688 - 0

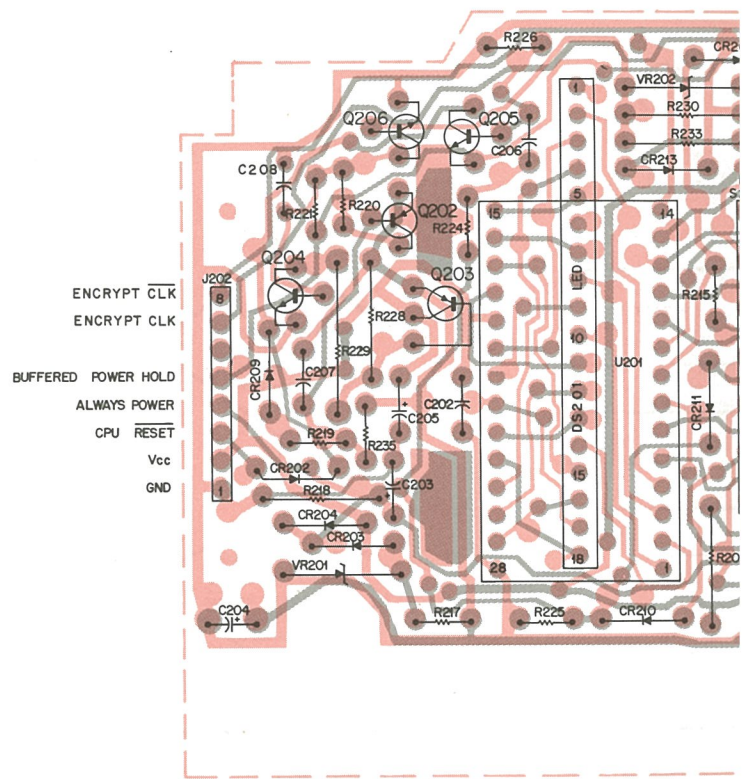

ENCRYPT CLK
 ENCRYPT CLK
 BUFFERED POWER HOLD
 ALWAYS POWER
 CPU RESET
 Vcc
 GND

**VERSION
UIT BOARD**

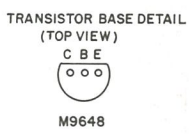
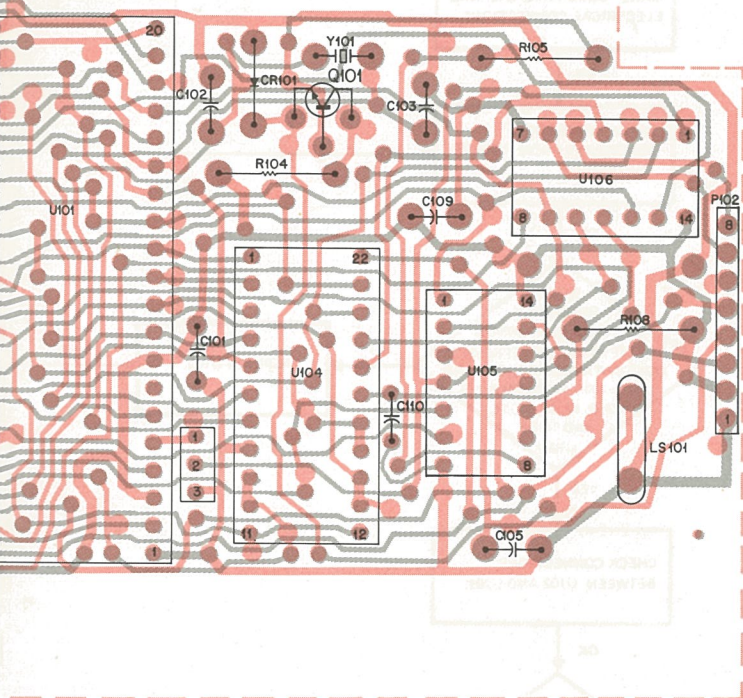

M COMPONENT SIDE

SOLDER SIDE @ BD-DEPS-42686-0
COMPONENT SIDE @ BD-DEPS-42687-0
OL-DEPS-42688-0

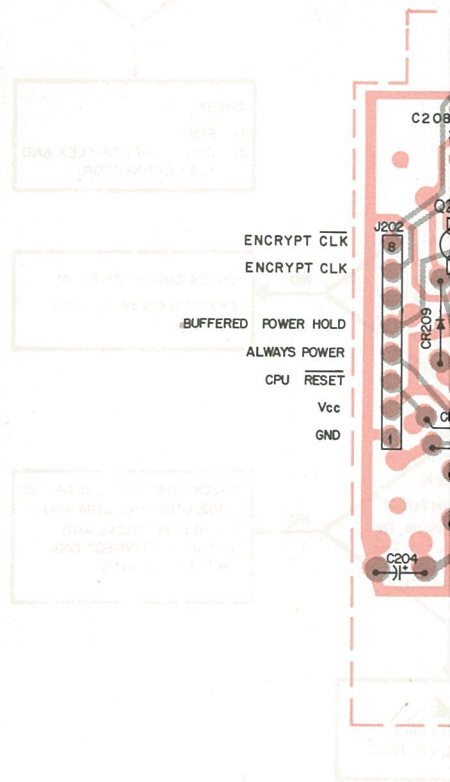

LATER VERSION INTERFACE CIRCUIT BOARD

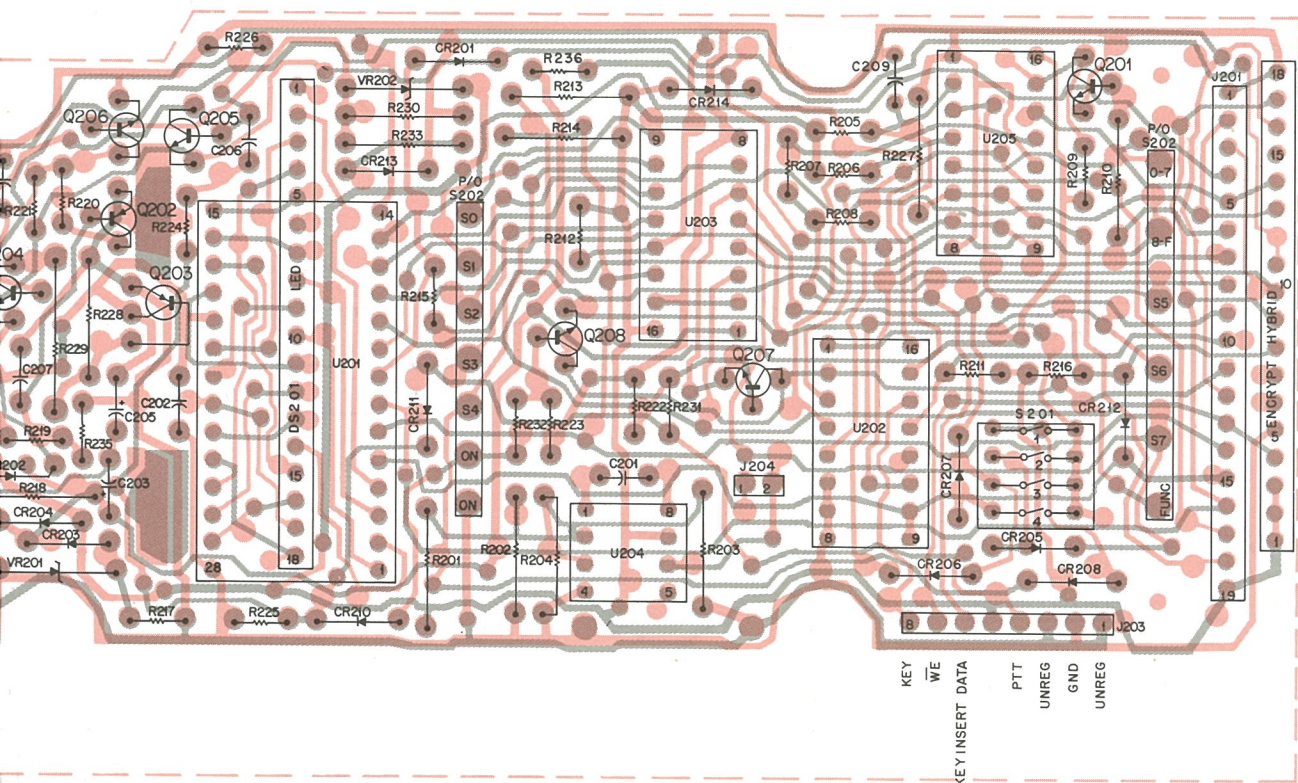

TRANSISTOR BASE DETAILS
(TOP SIDE)

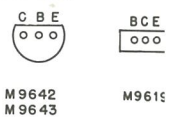

M9642 M9643 M9615

SHOWN FROM COMPONENT SIDE

SOLDER SIDE ● BD DEPS-42690-0
 COMPONENT SIDE ● BD DEPS-42691-0
 OL DEPS-42692-0

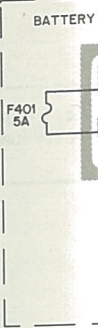

**LATER VERSION
RFACE CIRCUIT BOARD**

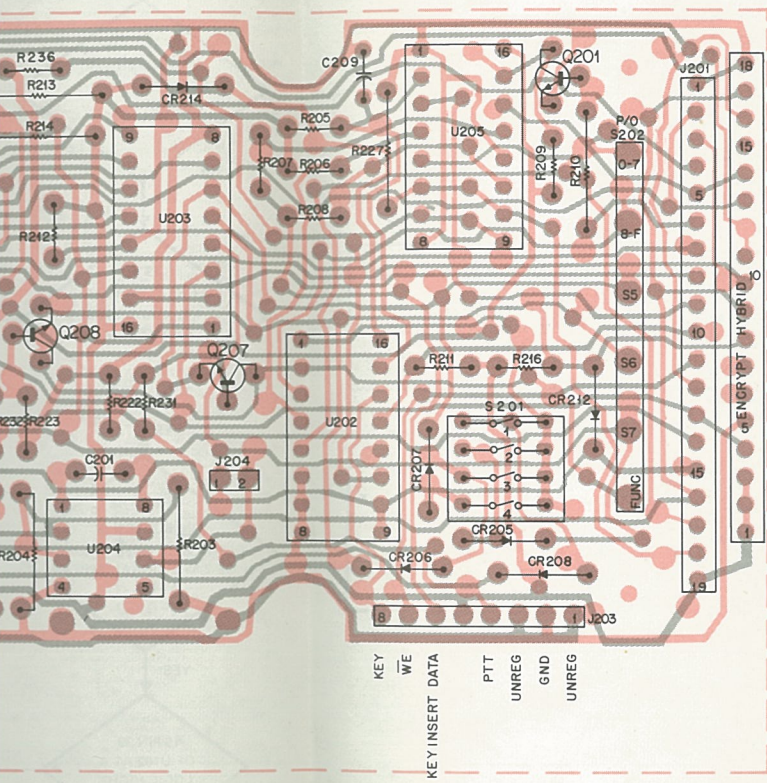

**TRANSISTOR BASE DETAILS
(TOP SIDE)**

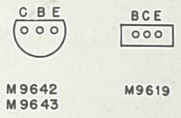

FROM COMPONENT SIDE

- SOLDER SIDE ● BD DEPS-42690-0
- COMPONENT SIDE ● BD DEPS-42691-0
- OL DEPS-42692-0

TO D
VAR
LO

TO D
VAR
LO

POWER CONTROL/FLEX

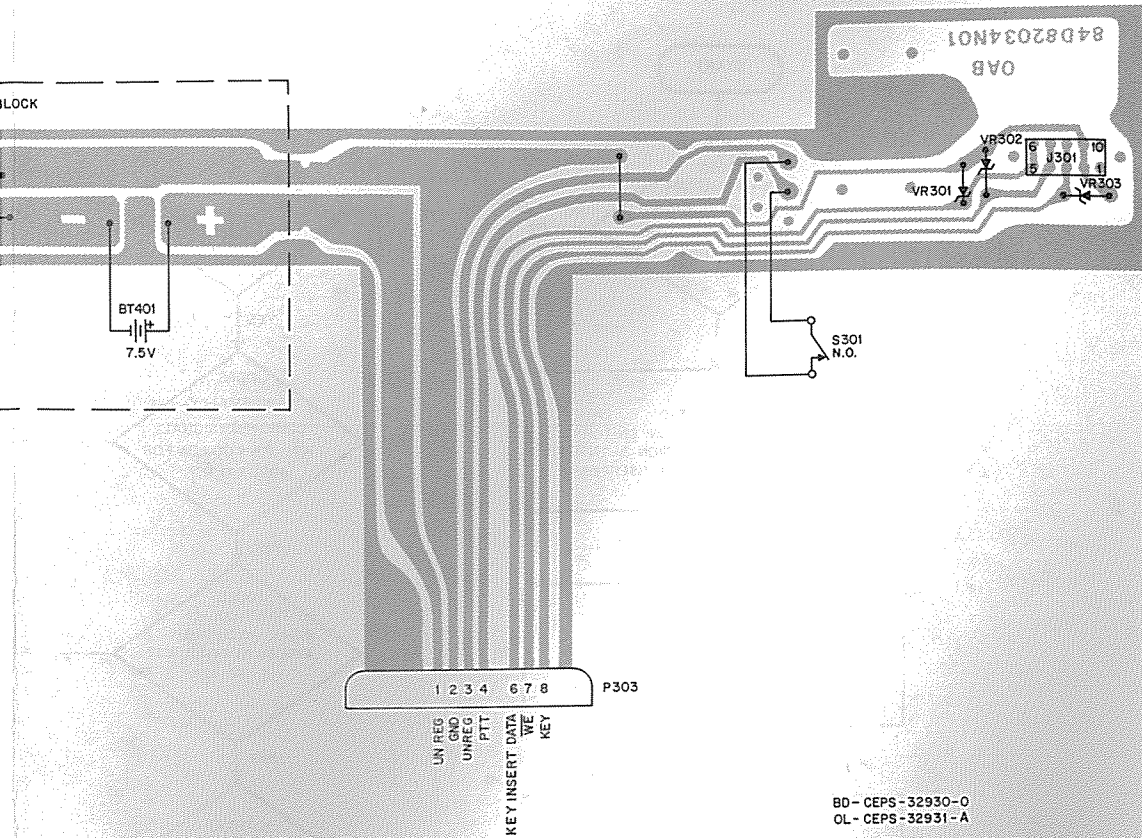

BD-CEPS-32930-0
OL-CEPS-32931-A

SHOWN FROM SOLDER SIDE

TKN8209B MX RADIO CABLE

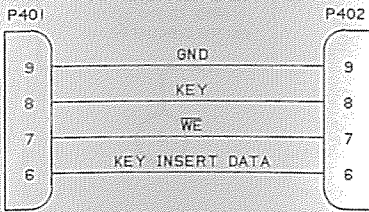

TO MX
RADIO

TKN8351A EXPO RADIO CABLE

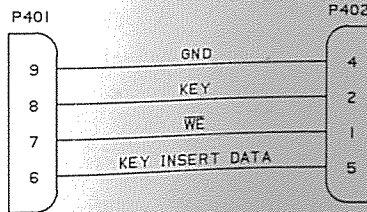

TO DES KEY
VARIABLE
LOADER

TO EXPO
RADIO

TKN8210B MICOR CABLE AND TKN8229B SYNTOR CABLE

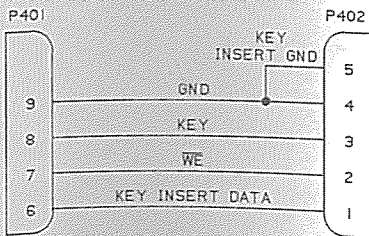

TO
MOBILE/FIXED
RADIO

BEP5-33011-B

INTERFACE BOARD CIRCUITRY

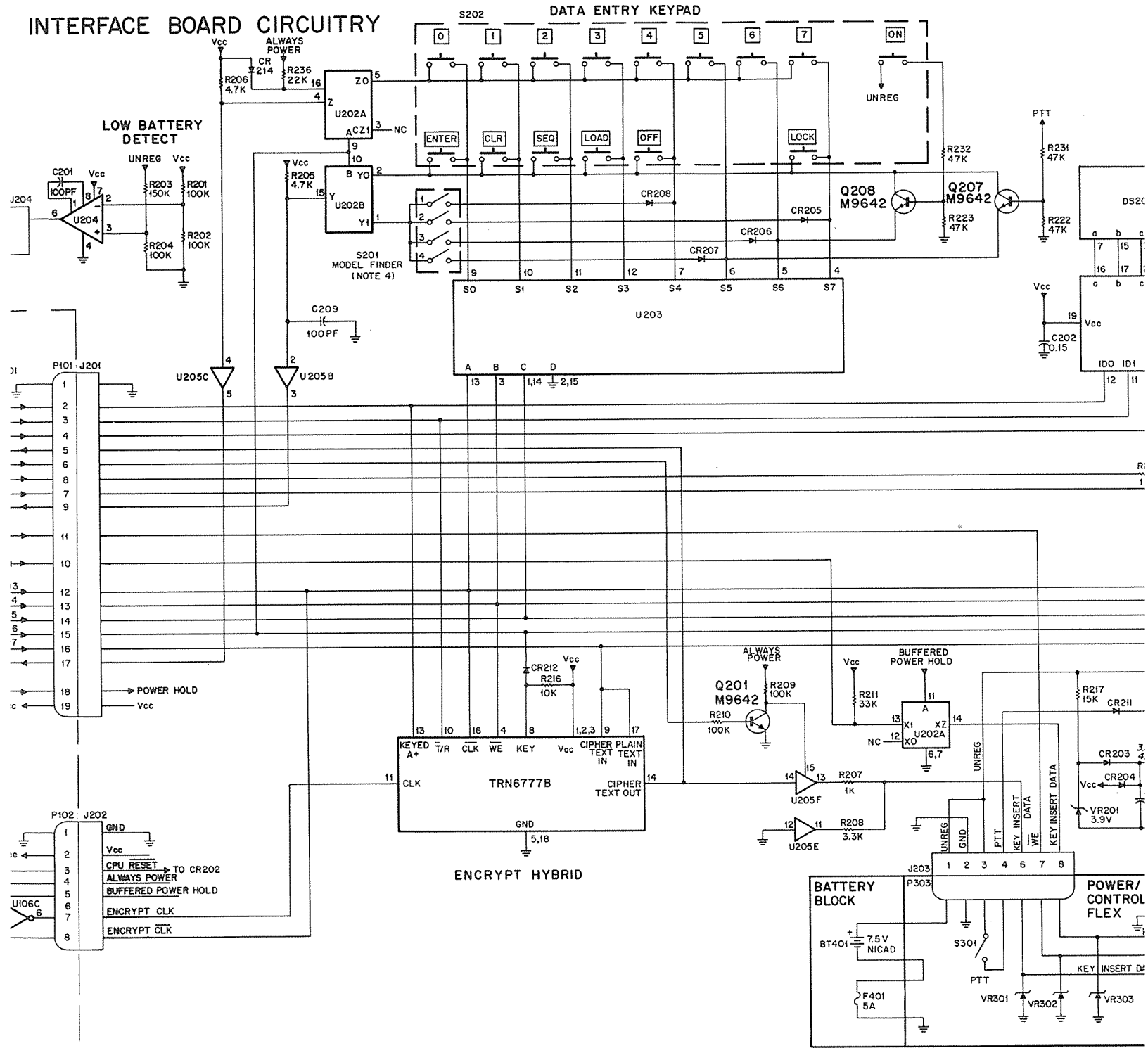

DATA OUTPUT DISPLAY AND DRIVER

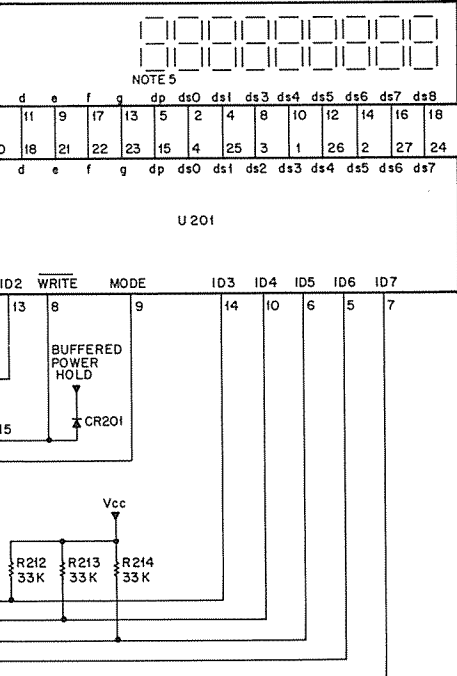

NOTES:

- UNLESS OTHERWISE INDICATED; RESISTOR VALUES ARE IN OHMS AND CAPACITOR VALUES ARE IN MICROFARADS.
- THIS DIAGRAM SHOWS POSITIVE LOGIC:
LOGIC "1" 5.0 V DC
LOGIC "0" 0 V DC
- IC CONNECTIONS FOR THIS BOARD ARE AS FOLLOWS:

REFERENCE DESIG.	POWER	GND	MFGR'S DESCRIPTION	TYPE
U101	8	1, 21	CPU	6802
U102	20	1	PIA	6821
U103	24	12	EPROM	2732
U104	22	8	RAM	5101
U105	14	7	3-INPUT AND	74LS11
U106	14	7	HEX INVERTER	74LS04
U201	19	28	LED DRIVER	7218B
U202	16	8	2-WAY MUX	4053
U203	16	8	3-TO-8 DECODER	74LS156
U204	7	4	FET OP AMP	3130
U205	16	8	HEX BUFFER	4503

4. MODEL FINDER SWITCH SETTINGS:

MODE	S201-		BIT RATE (KHZ)	S201-	
	3	2		4	1
DVP	X	0	9.6	1	1
FED DES	0	1	12	1	0
NON-FED DES	1	1	16	0	1
			24	0	0

5. THIRD DIGIT OF LED DISPLAY NOT USED.

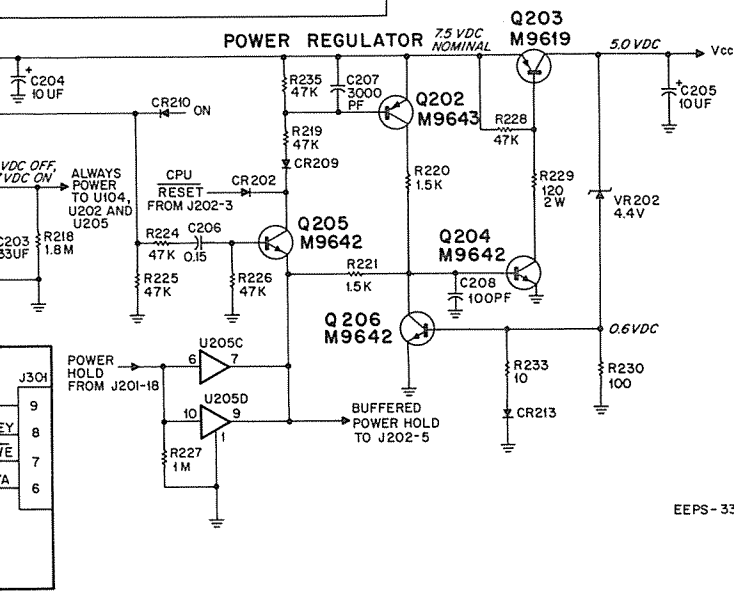

EEPS-33042-C

*DVP Code Inserter
Schematic Diagram and Circuit Board Detail
Motorola No. PEPS-42693-O
(Sheet 2 of 2)
12/5/85-UP*

CPU BOARD CIRCUITRY

INTERFACE BOA

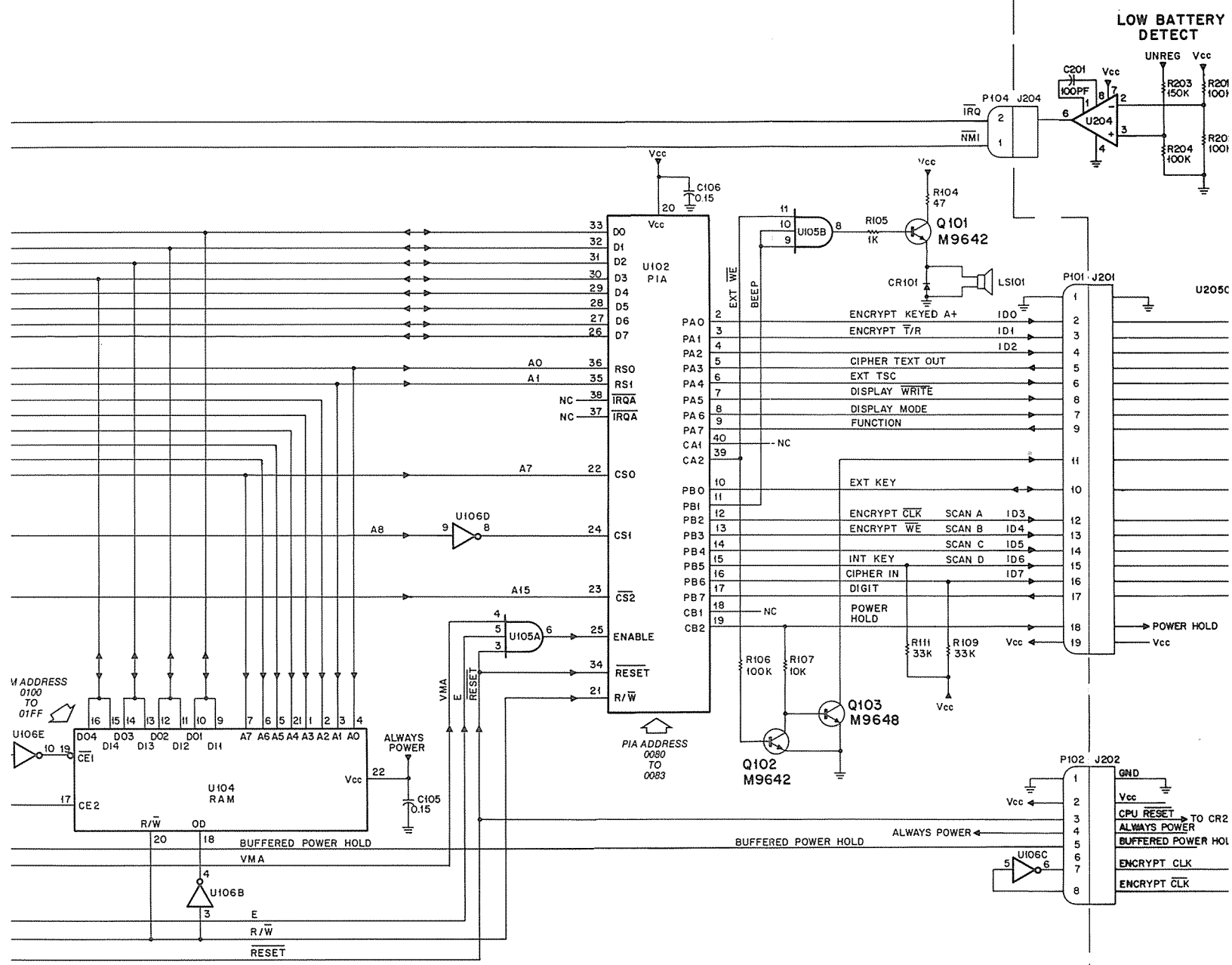

RD CIRCUITRY

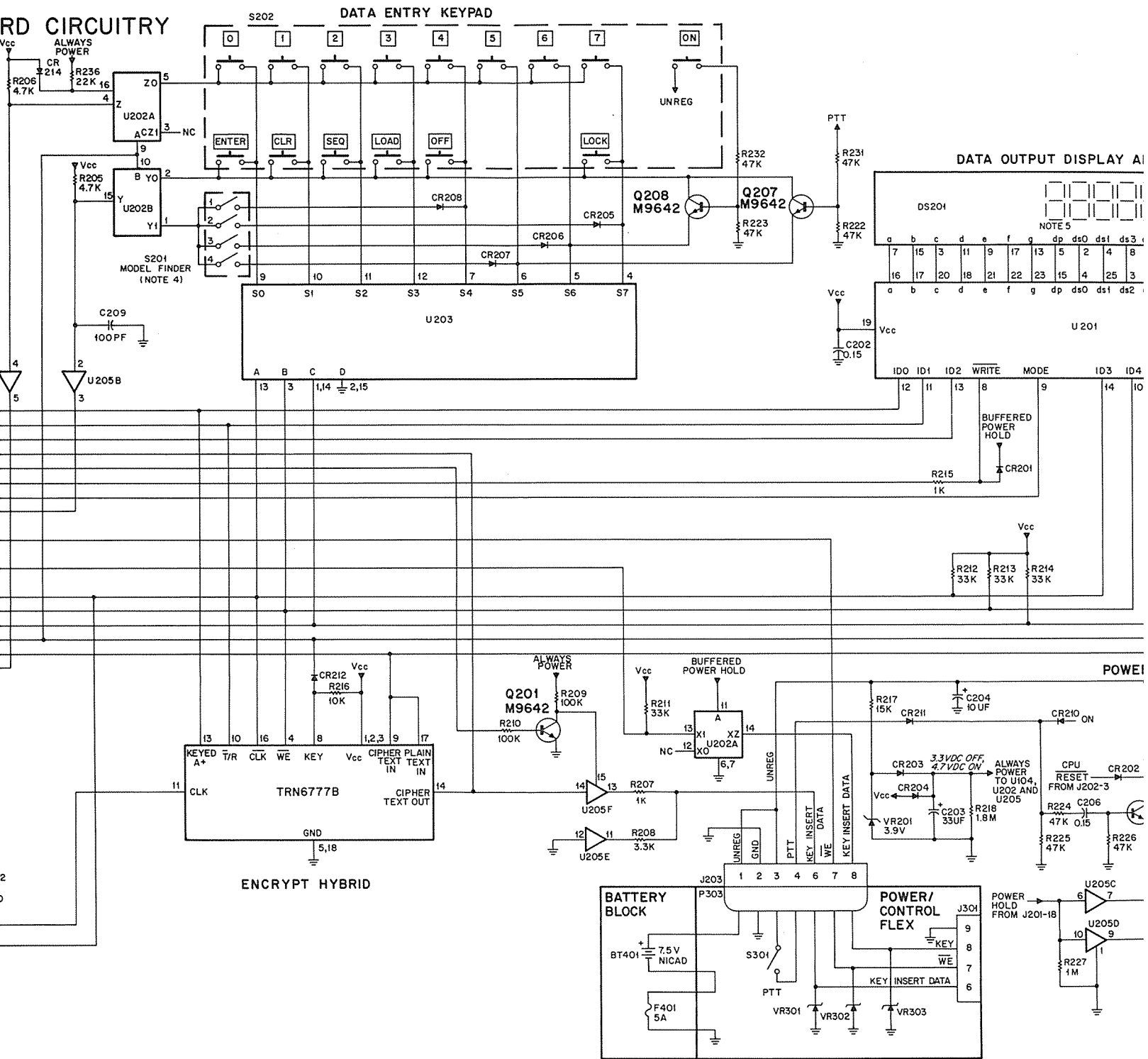

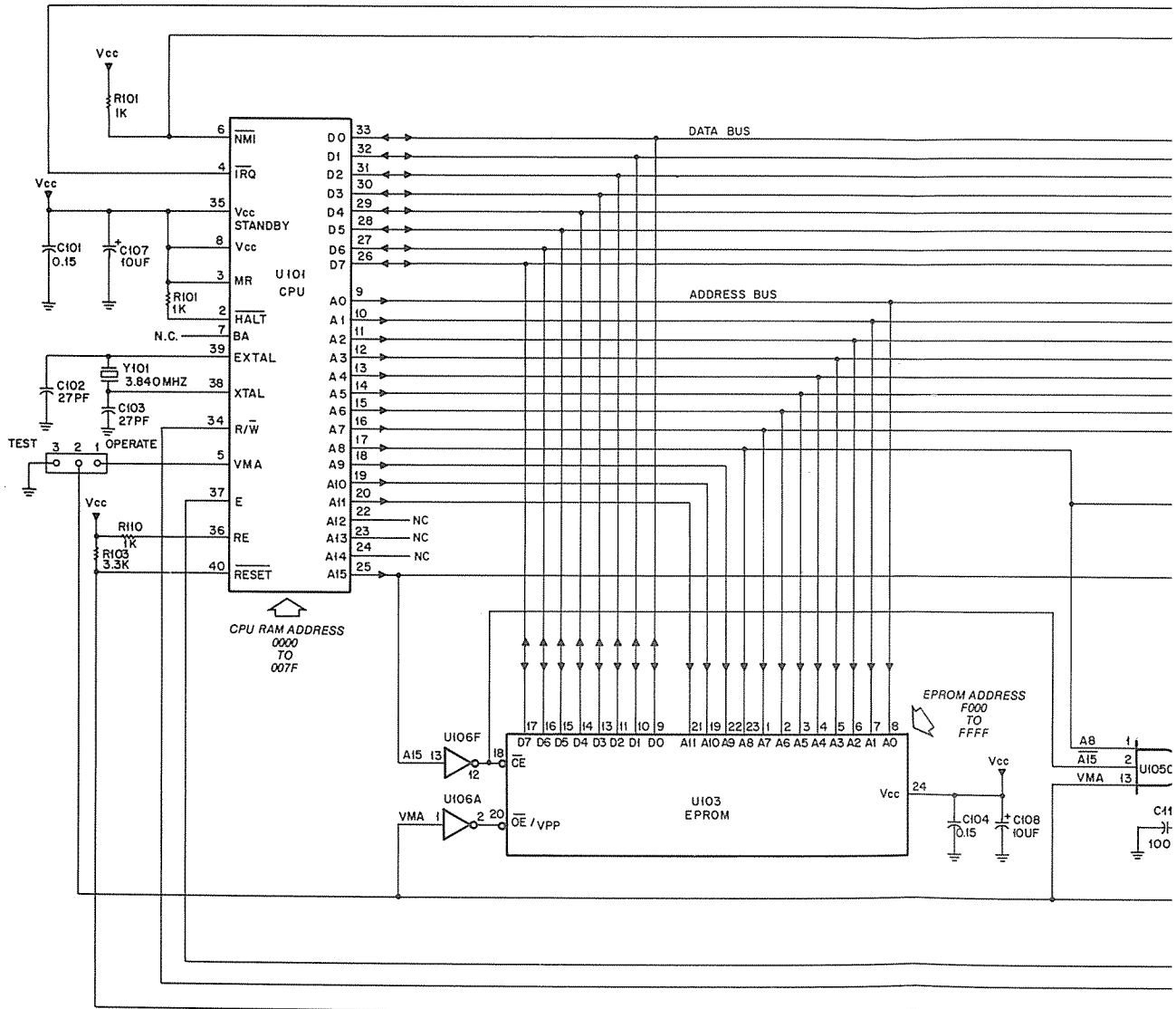

CPU BOARD CIRCUITRY

INTERFACE E

